



[www.BoeschPumps.com](http://www.BoeschPumps.com)

**2" FULL FREE PASSAGE  
SUBMERSIBLE SEWAGE PUMP**

**BC SERIES**

**60 HZ**



**BOESCH PUMPS INC**  
Art Chibli  
(305) 999-1769  
[achibli@boeschpumps.com](mailto:achibli@boeschpumps.com)  
14031 SW 143rd Court Miami, FL 33186

## BC SERIES

SERIES 60HZ

2" FULL FREE PASSAGE  
SUBMERSIBLE SEWAGE PUMP



BC Series auto coupling foot



Elbow Kit (Optional)



Vortex Impeller

### Features

- Vortex impeller design
- 2" discharge with PT inner thread
- 2" (50mm) solid free passage
- EKK Eagle Burgmann double mechanical seal CA/CE & SIC/SIC
- Stainless Steel motor housing

### Applications

- For heavy-duty applications with soiled biological wastewater, sewage, rainwater
- For both domestic and professional use

### Data Chart

Type	Output		Discharge Inch	F.L.A.			Rated		Maximum		Free Passage mm	Weight(W/O Cable)	
	HP	KW		1ø 230V	3ø 230V	3ø 460V	Head FT	Cap. GPM	Head FT	Cap. GPM		1ø-kg	3ø-kg
BC50	0.5	0.37	2"	4.5A	3A	1.5A	15	55	24	95	50	12.9	12.9
BC50Q	0.5	0.37	2"	4.5A	3A	1.5A	15	50	22	95	50	14.3	14.3
BC75	0.75	0.55	2"	5.5A	3.6A	1.8A	19.7	65	31	106	50	13.9	13.9
BC75Q	0.75	0.55	2"	5.5A	3.6A	1.8A	19.7	60	28	105	50	15.3	15.3
BC100	1	0.75	2"	7A	5A	2.5A	23	75	37.7	125	50	15.4	15.4
BC100Q	1	0.75	2"	7A	5A	2.5A	23	70	33.5	125	50	16.8	16.8
BC150	1.5	1.1	2"	9.3A	6.2A	3.1A	26	105(100)	46.5	158.5	50	24.2	24.2
BC150Q	1.5	1.1	2"	9.3A	6.2A	3.1A	26	100(95)	43	158.5	50	26.2	26.2
BC200	2	1.5	2"	10.5A	7A	3.5A	36	105	55	190	50	25.2	25.2
BC200Q	2	1.5	2"	10.5A	7A	3.5A	36	100	52.5	191	50	27.2	27.2

» BC series standard version features a vertical, threaded outlet pump body.  
» (Q) in the name-coding identifies the pump with horizontal flanged outlet.

» Auto coupling foot is suitable for BC-Q type models.  
» All single-phase pumps can be equipped with float switch upon request.  
» Elbow Kit is optional for BC-Q horizontal flanged outlet pump.

### Specifications

	Liquid Temperature	0~40°C (32~104°F)
	Submersible depth	10M
<b>Motor Part</b>	Frequency	60Hz
	Pole	2 Pole
	Type	Dry Type
	Insulation	Class B
	Protection	IP 68
	Protector	Auto-cut
<b>Pump Part</b>	Bearing	Ball Type
	Mechanical Seal	Double Mechanical Seal
	Impeller	Vortex Impeller

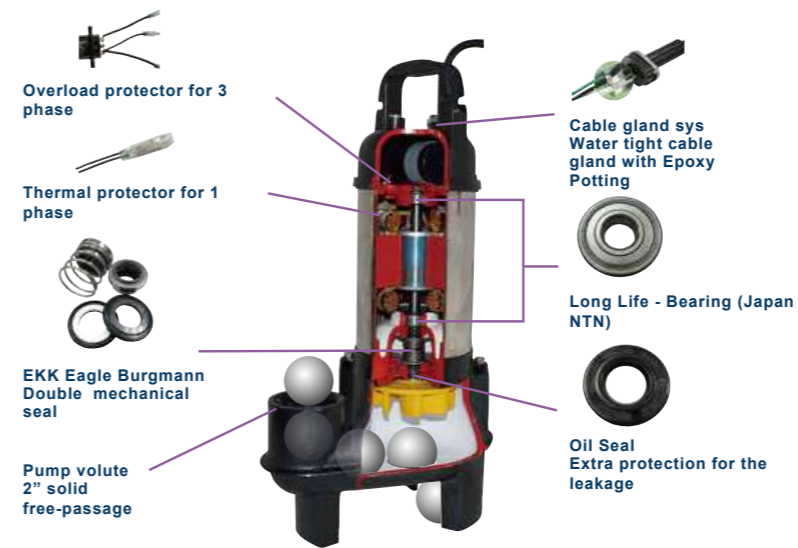

BC Series ( Q ) with flanged discharge



BC Series with Elbow Kit

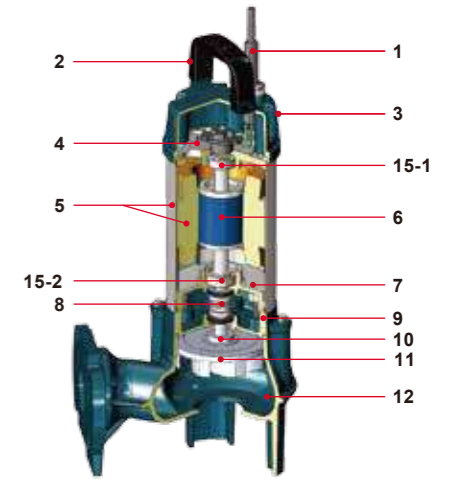

### Parts and Material List

No.	Part	Material
1	Cable	H07RN-F/SJTOW/STOW
2	Handle	Nylon6
3	Motor Cover	PA66+30GF (0.5~1HP) ASTM A48 Class 30 (1.5~2HP)
4	Bracket	ASTM A48 Class 30
5	Motor Housing + Stator	AISI 304
6	Shaft with Rotor	AISI 410
7	Oil Chamber	ASTM A48 Class 30
8	Mechanical Seal	Upper : CA / CE Lower : SIC / SIC
9	Seal Housing	ASTM A48 Class 30
10	Lip Seal	BUNA N
11	Impeller	ASTM A48 Class 30
12	Pump Casing	ASTM A48 Class 30
15-1	Upper Bearing	NTN/TPI
15-2	Lower Bearing	NTN/TPI

TPI is a family brand of NTN group.

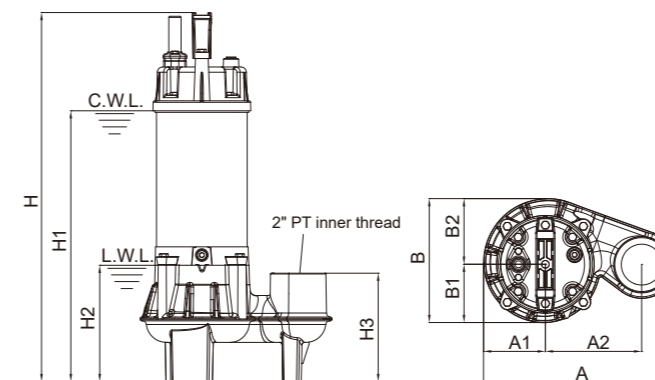

BC50~200

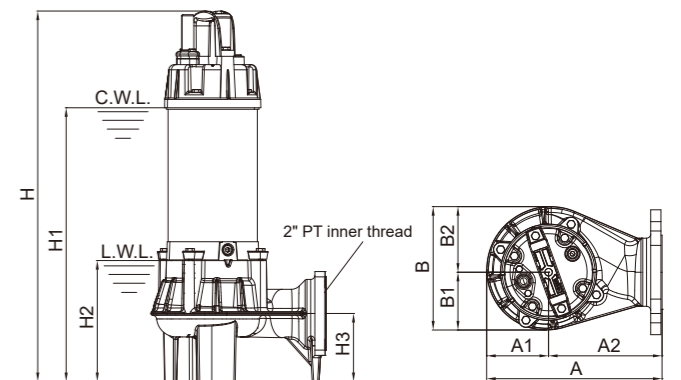

BC50Q~200Q

### Dimensions (mm)

Type	A	A1	A2	B	B1	B2	H	H1	H2	H3
BC50	260	89	125	170	90	80	466	336	151	141
BC50Q	235	85	150	170	85	85	470	342	161	90
BC75	260	89	125	170	90	80	482	352	151	141
BC75Q	235	85	150	170	85	85	486	358	161	90
BC100	260	89	125	170	90	80	496	366	151	141
BC100Q	235	85	150	170	85	85	500	372	161	90
BC150	272	93	130	187	87	100	506	376	151	143
BC150Q	248	93	155	190	95	95	510	373	158	90
BC200	272	93	130	187	87	100	520	396	151	143
BC200Q	248	93	155	190	95	95	530	393	158	90

## MOTOR / PUMP SPECIFICATIONS

ITEM		DESCRIPTION
LIMITS	Liquid Temp	0~40°C
	Application	Commercial / Industrial / Municipal use
TYPE	Frequency	60Hz
	Motor	2P (3450RPM) Dry Motor
	Insulation	Class B
	Start Method	Direct On Line
	Protection	IP 68
	Protector	Auto-Cut
	Bearing	Ball Type
	Mech. Seal	Dual. Mechanical Seal
	Impeller	Vortex Impeller
	MATERIAL	Motor Cover
Motor Housing+Stator		AISI 304
Shaft with Rotor		AISI 410
Mech. Seal		Upper: CA/CE; Lower: SIC/SIC
Pump Casing		ASTM A48 Class 30
Impeller		ASTM A48 Class 30
Cable	H07RN-F / SJTOW / STOW	



## MOTOR / PUMP DATA CHART

MODEL	OUTPUT		DISCHARGE INCHES	PHASE VOLTAGE	1Ø			FREE PASSAGE INCHES	WEIGHT W/O CABLE LBS
	HP	KW			115V	208V	230V		
BC50/1	0.5	0.37	2	FULL LOAD AMPS	9A	5A	4.5A	2	29
BC75/1	0.75	0.55	2		11A	6A	5.5A	2	31
BC100/1	1	0.75	2		14A	7.7A	7A	2	34
BC150/1	1.5	1.1	2		18.6A	10.3A	9.3A	2	53
BC200/1	2	1.5	2		-	11.6	10.5A	2	55

MODEL	OUTPUT		DISCHARGE INCHES	PHASE VOLTAGE	3Ø			FREE PASSAGE INCHES	WEIGHT W/O CABLE LBS
	HP	KW			208V	230V	460V		
BC50/3	0.5	0.37	2	FULL LOAD AMPS	3.3A	3A	1.5A	2	29
BC75/3	0.75	0.55	2		4A	3.6A	1.8A	2	31
BC100/3	1	0.75	2		5.6A	5A	2.5A	2	34
BC150/3	1.5	1.1	2		6.9A	6.2A	3.1A	2	53
BC200/3	2	1.5	2		7.7A	7A	3.5A	2	55

## MOTOR / PUMP CONSTRUCTION MATERIAL

PART	MATERIAL
Cable	H07RN-F/STJOW/STOW
Handle	Nylon 6
Motor Cover	PA66+30GF (0.5~1HP)
Motor Cover	ASTM A48 Class 30 (1.5~2HP)
Bracket	ASTM A48 Class 30
Motor Housing + Stator	AISI 304
Shaft with Rotor	AISI 410
Oil Chamber	ASTM A48 Class 30

PART	MATERIAL
Mechanical Seal	Upper: CA / CE
Mechanical Seal	Lower: SIC / SIC
Seal Housing	ASTM A48 Class 30
Lip Seal	BUNA N
Impeller	ASTM A48 Class 30
Pump Casing	ASTM A48 Class 30
Upper Bearing	NTN/TPI

## PUMP PERFORMANCE REPORT

MODEL	BC100	HEAD	RATED
FREQUENCY	60 HZ	CAPACITY	20 ft / 6 m
DISCHARGE	2 inches / 50 mm	POLE / RPM	100 gpm / 378 lpm
OUTPUT	1 hp / 0.75 kW		2 poles / 3450 rpm

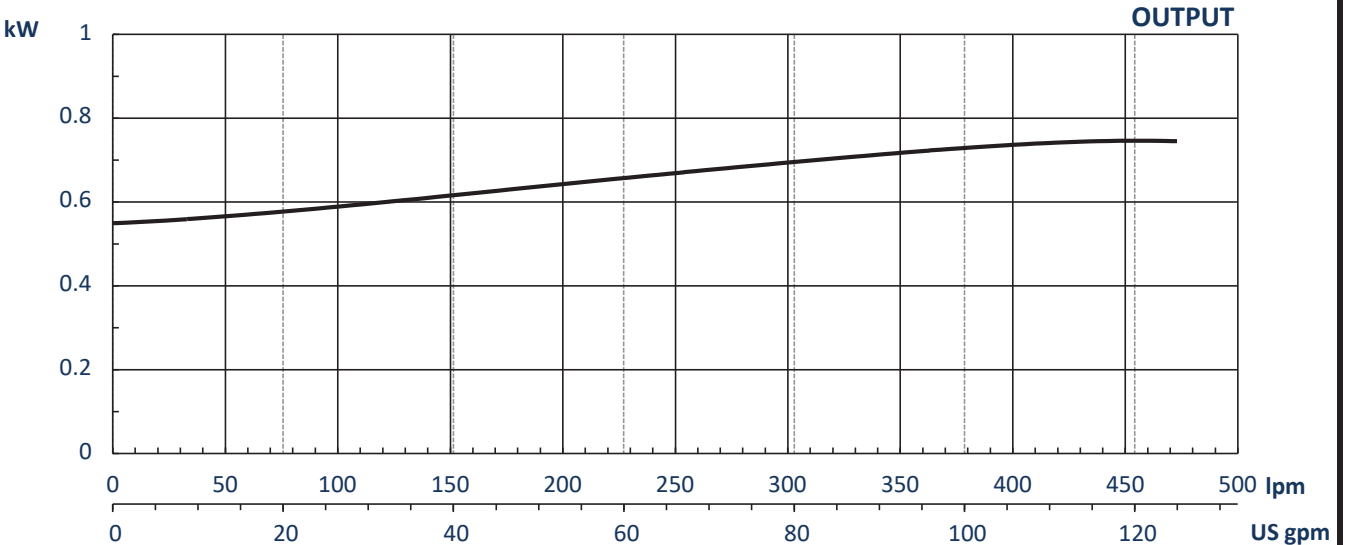
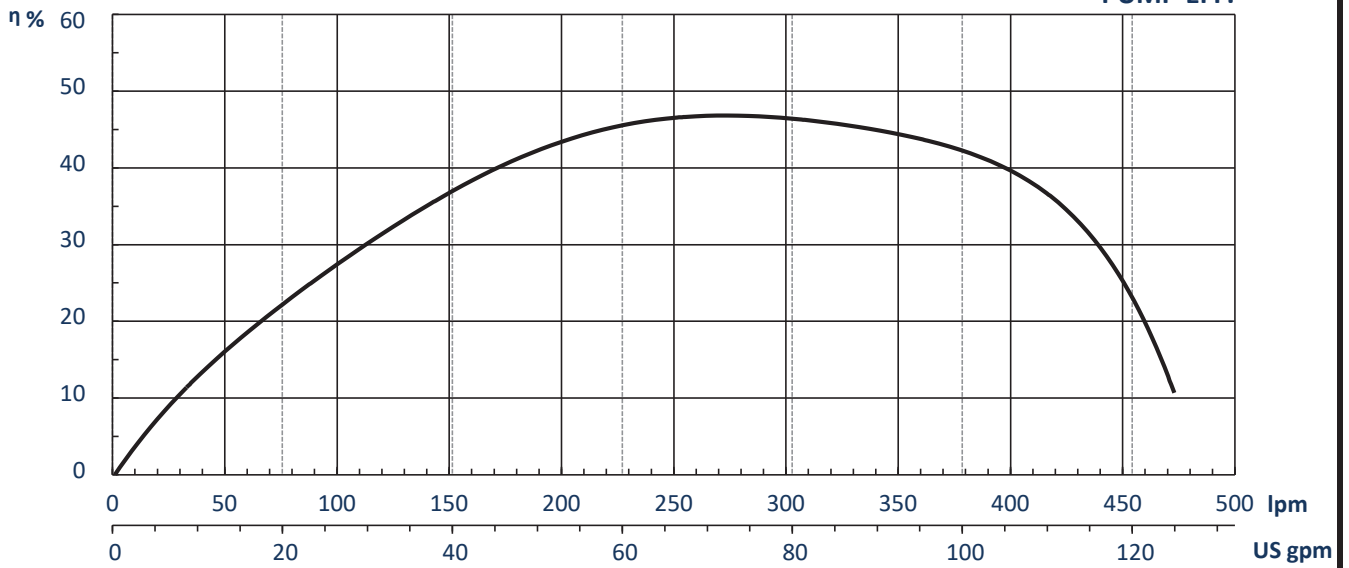
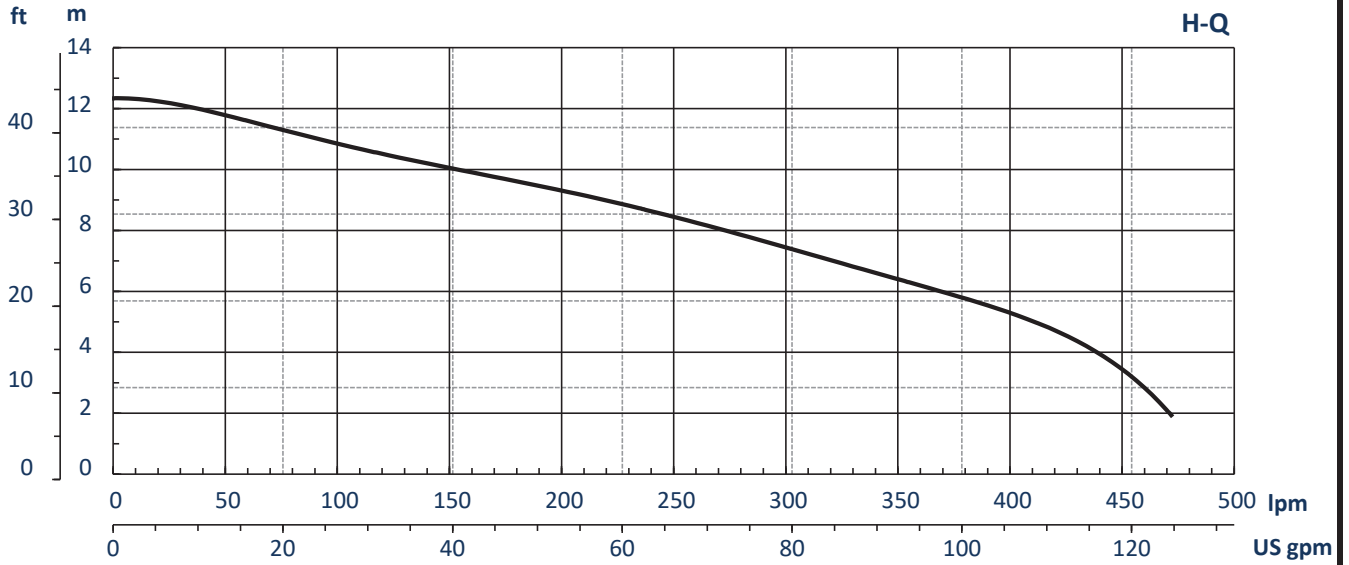

### DIMENSIONAL DRAWING

MODELS: BC50 - BC200 (0.5 - 2HP) THREADED DISCHARGE

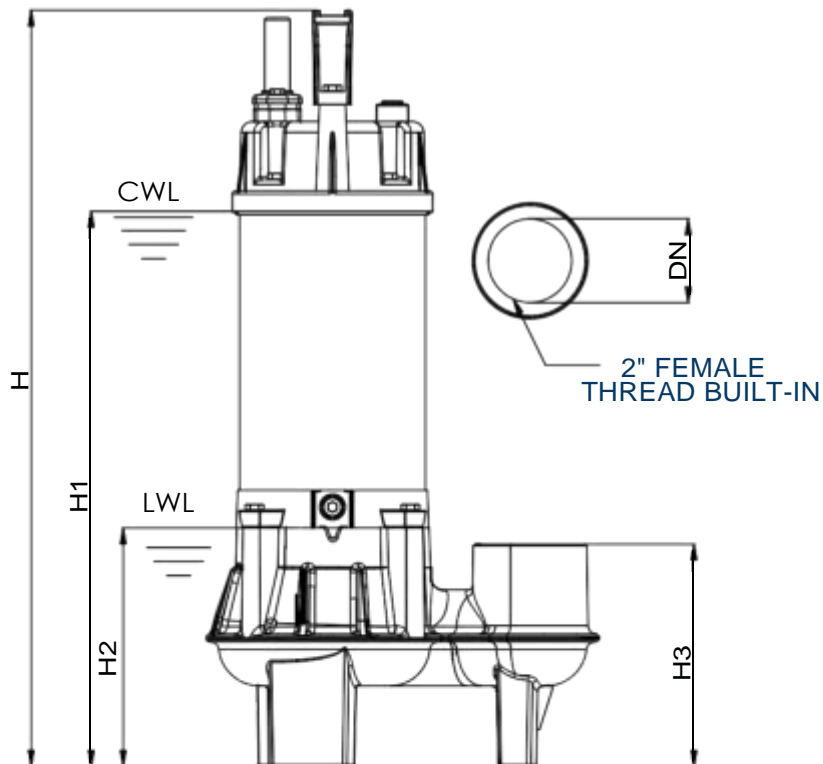
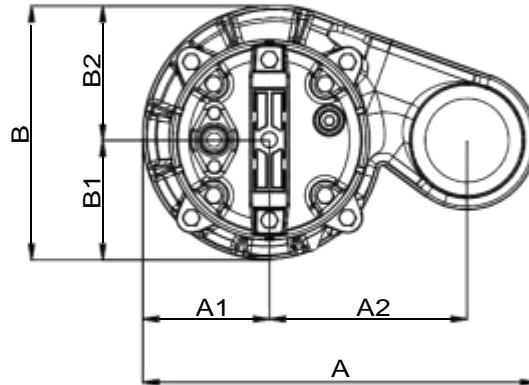

**DIMENSIONS: INCHES**

**WEIGHT: LBS**

**PIPE CONNECTION TYPE: NPT**

MODEL	A	A1	A2	B	B1	B2	DN	H	H1	H2	H3	WT
BC50	10.24	3.50	4.92	6.70	3.54	3.15	2	18.35	13.23	5.94	5.55	28.40
BC75	10.24	3.50	4.92	6.70	3.54	3.15	2	18.98	13.86	5.94	5.55	30.60
BC100	10.24	3.50	4.92	6.70	3.54	3.15	2	19.53	14.41	5.94	5.55	34.00
BC150	10.71	3.66	5.12	7.36	3.43	3.94	2	19.92	14.80	5.94	5.63	53.24
BC200	10.71	3.66	5.12	7.36	3.43	3.94	2	20.47	15.59	5.94	5.63	55.44

**CWL: CONTINUOUS RUNNING WATER LEVEL**

**LWL: LOWEST RUNNING WATER LEVEL**

**WT: WEIGHT WITHOUT CABLE**