

## BTW2018T-140W-40 DUPLEX VARIABLE SPEED BOOSTER PUMP SYSTEM

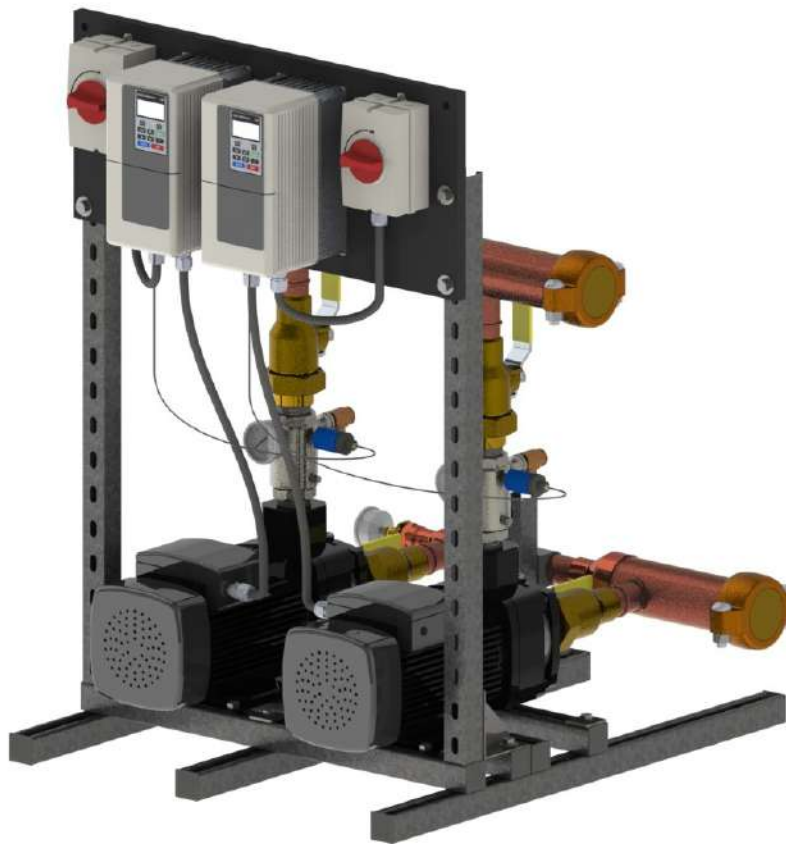

The **BTW2018T-140W-40 Duplex Booster Pump System** is equipped with centrifugal pumps regulated by variable frequency drives that control the pump to maintain constant pressure regardless of varying demand or fluctuating incoming pressure.

System is built to fit through a 30" doorway.

VFD drives will ALTERNATE lead pump every 24 hours of run time. Second pump will remain on standby.



*All parts shown included  
Actual system components may vary  
Some assembly required*

### Lead-Free (Wetted) components:

- Pumps: Cast Iron or SS Option (upgrade)
- Relief valves: LF Brass
- Pressure Gauges: LF Brass
- Transducers: Stainless Steel
- Check valves: Stainless Steel
- Ball Valves: LF Brass
- Manifolds: Type L Copper
- Fittings: LF Brass or SS

\* All lead-free brass shall contain <.25% Pb

### Technical Specifications:

**Pumps:** Walrus [12T-3K]

**Horse Power:** 2 HP per pump

**VF Drives:** Yaskawa

**Flow Rate:** 140 GPM (70 GPM per pump)

**Boost:** 40 PSI

**Set Pressure:** 65 PSI (unless otherwise specified)

**Manifolds:** 3 Inch

**Tank:** 26 Gallon expansion tank

**Frame:** 29" W X 42" H X 36" D

**Power options:** Two Independent circuits required  
208-220V/1PH  
208-220V/3PH  
360-480V/3PH

*Specify when ordering*

*Performance curve for each pump*

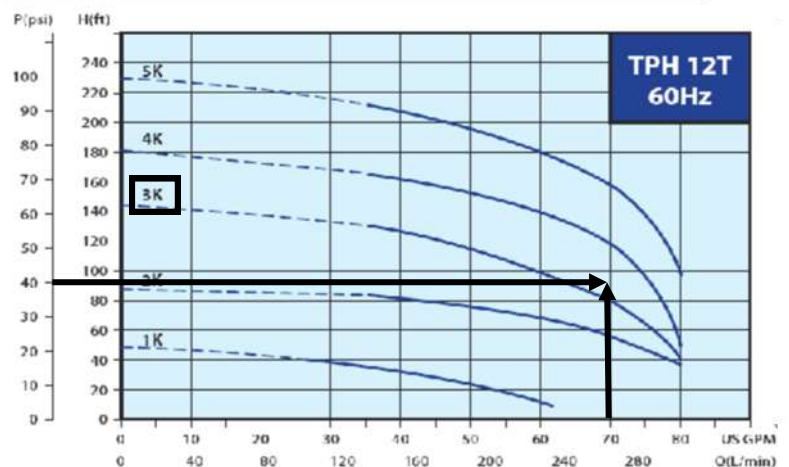

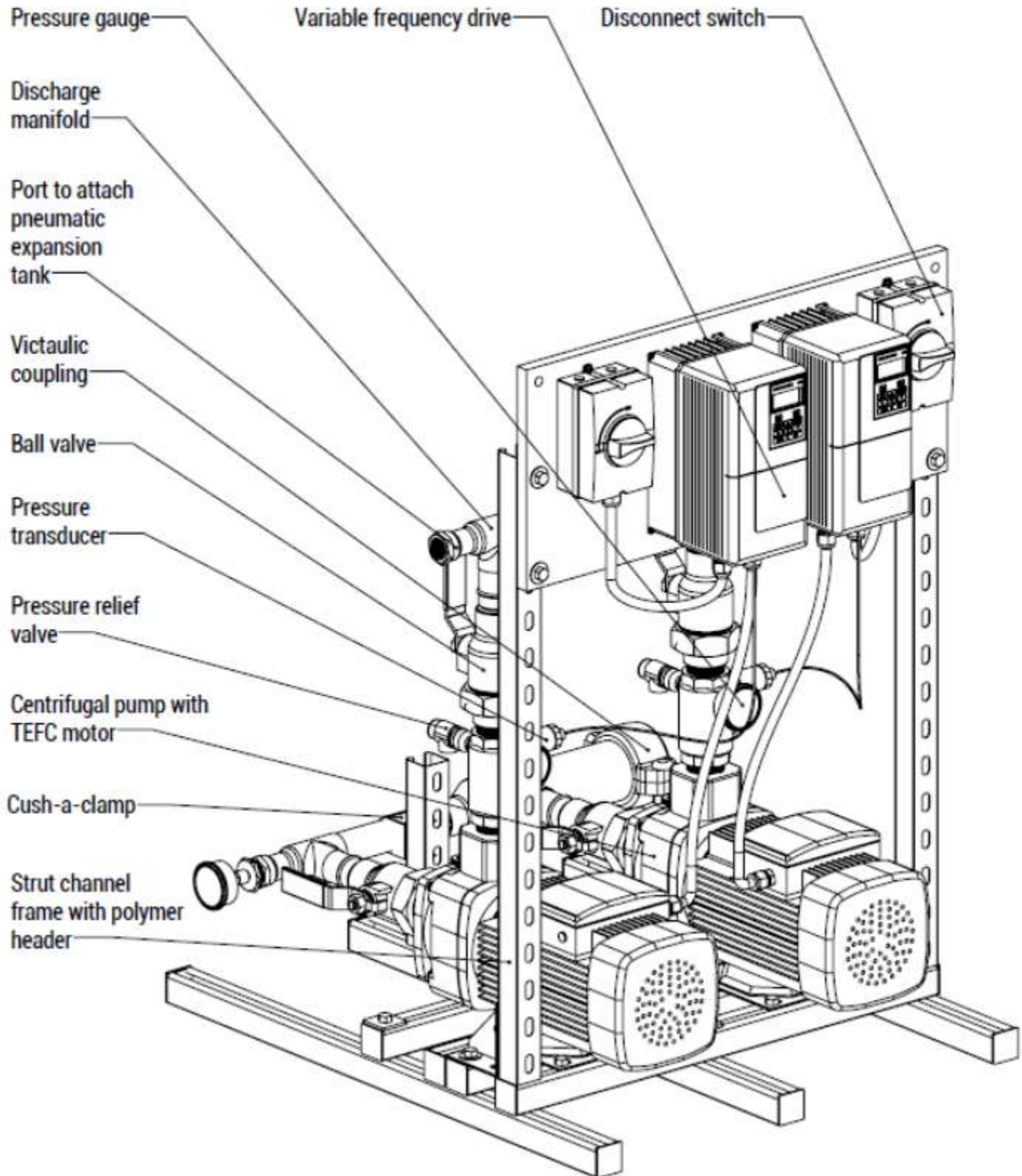

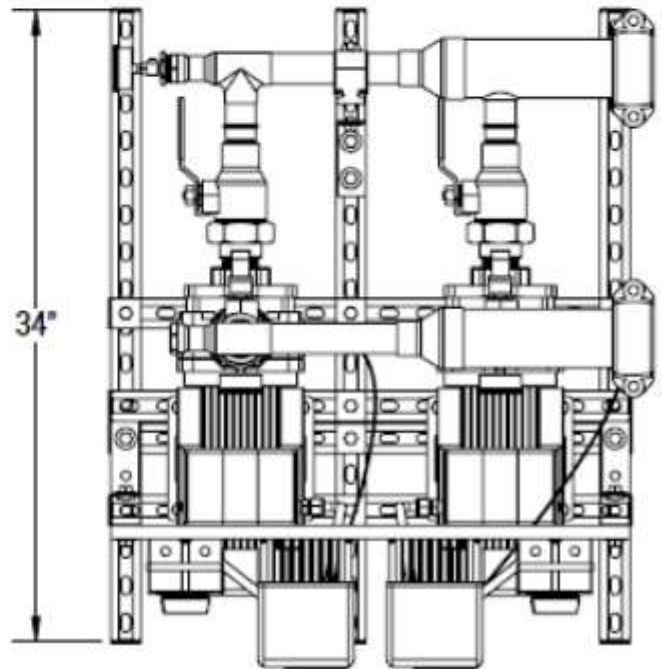
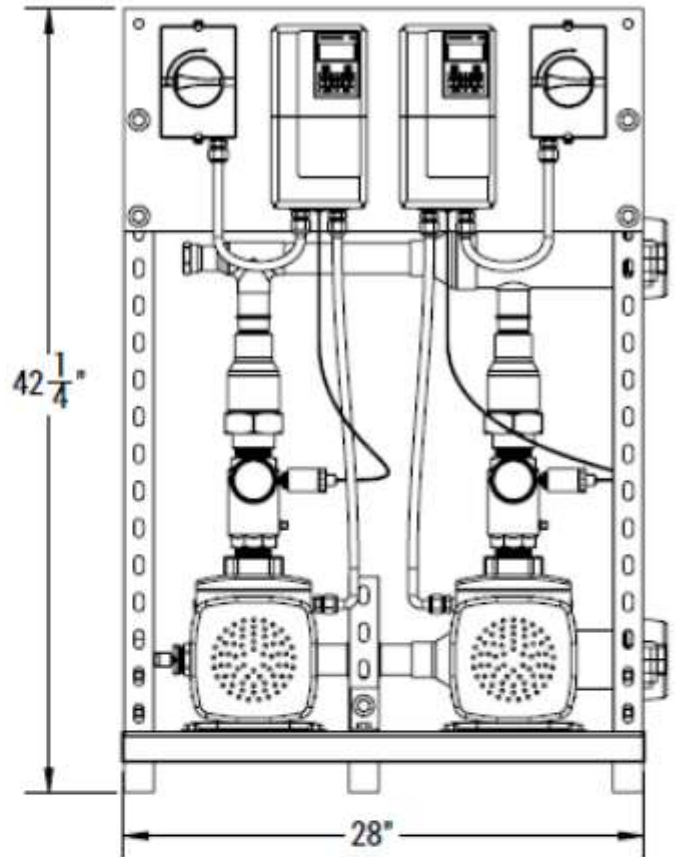
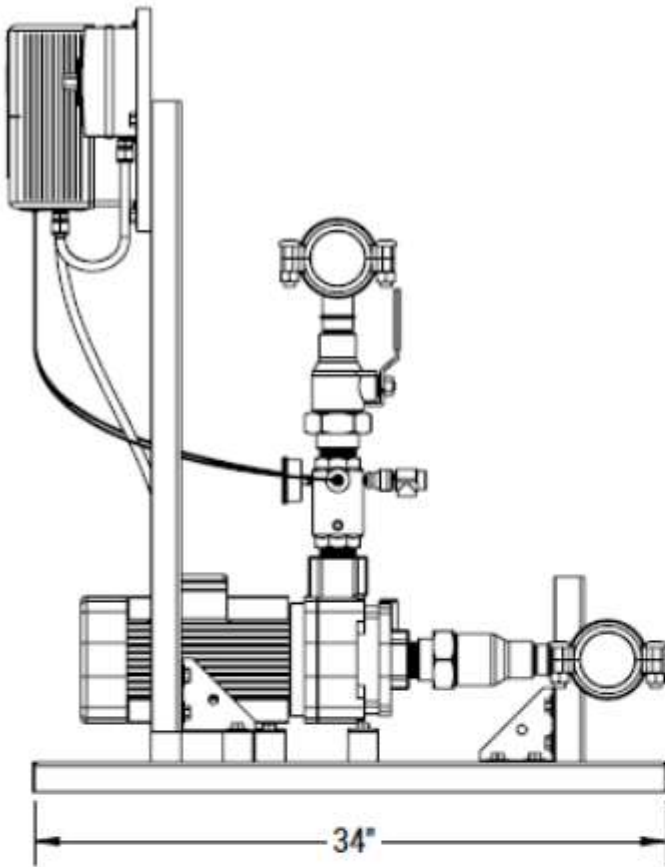

**Assembled Units:**

- All “wetted surfaces” shall be lead free (<.25% Pb) in conformance with the 1/4/14 federal law
- Shall include a separate and independent variable frequency drive (VFD) for each pump with a pressure transducer, pressure gauge, and relief valve. Piping and frame shall not interfere with access to the controls
- Each pump shall include isolation valves on both the suction and discharge piping
- Each pump shall have a separate and independent disconnect box
- Shall be mounted on a frame for ease of transport and installation.

**Variable frequency drive:**

- Will ALTERNATE the lead pump every 24 hours (field adjustable) of run time. The lag pump shall be in standby
- Shall have hands-off automatic (HOA) capability
- Rated to operate using specified power requirement. The drive efficiency shall be 98% or better
- Have UL approval with all factory installed options and preset values and/or last saved data values will remain available to the operator after power outage
- Shall have at least NEMA 1 rated conduit enclosure
- The program will protect the pumps against damaging hydraulic conditions such as:
  - Motor overload, Pump overflow surges, Loss of prime due to incoming water supply interruption, Hunting
  - Protection from overload through frequency/current optimization
  - Protection from hydraulic damage by restricting the pumps to operate beyond their published end of curve
- Shall have the ability to automatically restart after an over-current, over-voltage, under-voltage or loss of input signal
- Shall have an operator control panel [keypad] for customization of parameters
- Shall include a feature to upload/download parameters into an external device to be used with another drive or the same drive
- Shall have a removable non-volatile memory device
- Shall be capable of accepting individual analog inputs from transducer. All transducer inputs must be wired to the variable frequency drive for continuous scan and comparison function
- Ladder logic program shall utilize a proportional - integral - derivative control function
- Shall display the following values:
  - Pump running/standby, Pump speed in Hz, User adjustable parameters such as PID set points, Motor frequency, Motor current, Threshold set points for PID error, Min operating frequency, Troubleshooting and diagnostics of faults

**Transducer:**

- The transducer shall be rated for required system pressure and shall be 4-20 mA analog
- Separate transducers shall be supplied for each variable frequency drive to ensure redundancy

**Centrifugal pump:**

- Shall have a cast iron casing with 304 stainless steel impellers. (All Stainless Steel pumps are an available upgrade)
- Shall have a 316 stainless steel shaft sleeve. Mechanical seal shall be rated to withstand pressure of up to 142 PSI
- Motor shall be to totally enclosed fan cooled (TEFC). and manufactured in compliance with CE, RoHS and CSA

**Pneumatic expansion tank:**

- Pneumatic expansion tank shall be rated for use with potable water with an operating pressure of a maximum 125 PSI
- Pre-charged to a pressure of 10 PSI below system operating pressure for system to run properly

**Manifolds, valves and fittings:**

- Manifolds are designed for either right or left access
- Shall be sized appropriately to allow water velocity not exceeding 10 ft/sec, to minimize cavitation and turbulence
- Check valves shall be silent and spring-loaded

**Installation:**

- Equipment shall be installed in accordance with applicable local building, electrical and plumbing codes
- Shall be installed indoors (unless otherwise specified) and protected from water spray

**Electrical**

Yaskawa VFD

UL 508C Power Conversion  
CSA 22.2 Industrial Controls

CE

RoHS

Lovato Shut-off

NEMA4



CE

RoHS

**Pumps**

Grundfos CM(I) SS Series

NSF 61



CE

Grundfos CR(I) SS Series

NSF 61



CE

Goulds 125MS Series

NSF 61



CE

Goulds BF Series

NSF 61

Walrus TPH Series

NSF 372

CE

RoHS

**Plumbing**

Bluefin BVT200 Ball Valves

NSF 61

Webstone BVT200 Ball Valves

NSF 61

Bonomi Check 1000012

NSF 61

CE

Flomatic VFD Check

NSF 61

Victaulic 607 "E" Coupling

NSF 61

Victaulic 660 Cap

NSF 61

Amtrol PL Tank

NSF 61

Watts PLT Tank

NSF 61

Manifolds / piping

Type L Copper

Fittings

Copper

Discharge Riser

Copper

CE

- Pressure Relief valve:

- SS 4-20mA Transducer:

- Pressure Gauges: CA AB1953

**Sealants**

Rectorseal Nokorode Flux

NSF 61

Worthington SILVER Solder

NSF 61

LocTite 567 Thread Sealant

NSF 61

Gasola Thread Sealant

NSF 61



**Warranty:** Provide VFD warranty, for one year from startup, not to exceed 18 months from the date of shipment. Warranty shall include parts, and labor allowance for repair hours.



### Performance Features (Drive)

- Ratings:
  - 1 to 5 HP at 200-240 VAC 1-Ph.
  - 1 to 25 HP (ND) at 200-240 VAC 3-Ph.
  - 1 to 25 HP (ND) at 380-480 VAC 3-Ph.
- Overload Capacity:
  - 120% for 60 sec. (Normal Duty)
- Control Methods: V/f Control, Open Loop Current Vector Control
- DC injection braking, ramp to stop
- Electronic reversing
- Adjustable accel/decel: 0.01 to 6000 seconds
- Controlled speed range:
  - 40:1<sup>(1)</sup> 100:1<sup>(2)</sup>
- Speed Regulation:
  - ± 0.5 to 1% with slip compensation<sup>(1)</sup>
  - ± 0.2%<sup>(2)</sup>
- Displacement power factor: 0.98
- Output frequency: 0 to 400 Hz
- Frequency resolution:
  - 0.01 Hz with digital reference
  - 0.06 / 60 Hz with analog reference
- Frequency accuracy:
  - 0.01% with digital command
  - 0.5% with analog command
- Volts / hertz ratio: infinitely adjustable pattern
- DC Injection braking: adjustable amplitude, duration, current limited
- Torque boost: full range, auto
- Power loss ride-thru: 0.5 sec.
- Speed search
- Auto restart
- 3 Critical frequency rejection settings
- Slip Compensation
- Energy Savings Function
- Enhanced PID with loss of feedback function

<sup>(1)</sup> V/f Mode

<sup>(2)</sup> Open Loop Current Vector Mode

### Design Features (Drive)

- Dual microprocessor logic
- Digital keypad operator, 5 digits
- LED status display
- Remote Mount Keypad Capability
- RJ-45 Style Digital Operator Connector
- 7 multifunction digital inputs
- 3 multifunction digital outputs
- Hardwire baseblock (EN954-1 Cat. 3)
- Programmable form C output contact for customer use: 1A at 250 VAC or 30 VDC
- 24 VDC control logic compatible with sourcing or sinking outputs (PNP or NPN)
- Carrier frequency: 15 kHz max; swing PWM
- 2 Remote speed references:
  - 0-10 VDC (20 kohms) or isolated 4-20 mA (250 ohms)
- Signal follower: bias and gain
- 2 programmable open collector outputs
- Analog monitor output:
  - 0-10 VDC proportional to output frequency or output current
- Approx. 400 parameters and monitors
- Digital pulse train input (33 kHz max.)
- Cooling fan controlled by drive run/stop
- RS-422/485 Modbus 115 kbps
- UL recognized electronic overload
- MTBF: 28 years
- NEMA 1 enclosure
- Side-by-Side mounting
- Maintenance monitors

### Protective Features (Drive)

- Current limit, stall prevention during accel, decel, and run
- Motor and drive overload
- Over voltage prevention function
- Instantaneous over current
- Short circuit
- Under voltage
- Heatsink overheat
- Ground fault protection
- Over/under torque
- Short circuit current rating: 30kA rms sym.

### Pump Control Features

- Operator keypad with intuitive pump language
- Hand-Off-Auto
- Programmable pump process set point
- Pump start level and start time
- Sleep protection
- Simplex, duplex and triplex control
- Automatic system restart
- No flow detection
- Low and high feedback set points
- Pre-charge low level control
- Thrust bearing control
- Automatic system stabilization
- Motor condensation pre-heat function

### Pump Protective Features

- Dry well
- Air in system
- Blocked impeller
- Pump over cycling
- No flow protection
- Loss of prime
- Transducer loss
- Over torque

### Pump Alarms and Messages

- Low feedback
- High feedback
- Low level
- Low water
- Pump over cycling
- No flow detection
- Loss of prime
- Pump fault
- Motor thermostat
- Pre-charge mode
- Thrust bearing active
- Start mode active
- Sleep mode active

## MULTISTAGE CENTRIFUGAL PUMP

**WALRUS**

MULTISTAGE CENTRIFUGAL PUMP

### TPH2T/4T/8T/12T

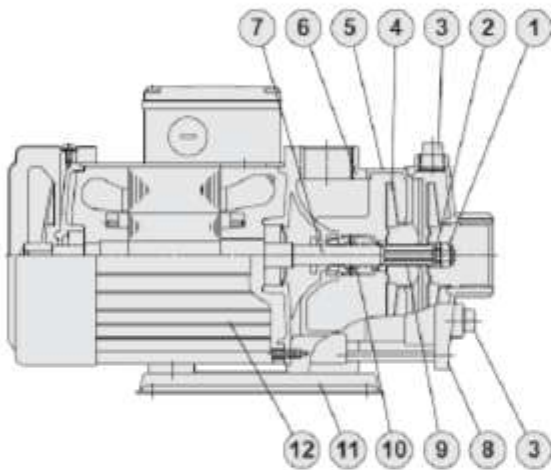

#### Motors:

- The pump is coupled with (TEFC) Totally Enclosed Fan Cooled, squirrel-cage motor.
- Nominal speed: 3500 rpm at 60Hz
- Protection class: IP54
- Insulation class: F

#### Pumps:

- Horizontal multi-stage centrifugal pump
- Non self-priming
- close coupled design
- Impellers mounted on extended motor shaft.

#### Materials

No.	Part name	Material		
		Standard	S series	N series
1	Lock Nut	SUS 316	SUS 316	SUS 316
2	Sleeve (Shaft End)	SUS 304	SUS 304	SUS 316
3	Water Plug	FC 20	SUS 304	SUS 316
4	Impeller	SUS 304	SUS 304	SUS 316
5	Intermediate Chamber	SUS 304	SUS 304	SUS 316
6	Pump Casing	FC 20	SUS 304	SUS 316
7	Shaft	SUS 304	SUS 304	SUS 316
8	Suction Chamber	FC 20	SUS 304	SUS 316
9	Sleeve	SUS 304	SUS 304	SUS 316
10	Mechanical Seal	Tungsten carbide + HNBR		
11	Mounted Base	Coating Steel	SUS 316	
12	Motor Shell	Aluminum alloy		

SUS 304 may be replaced by SUS316 depended on stock availability.

#### Operating Limits:

- Ambient temperature: Max. 104°F (40°C)
- Liquid temperature range: 32°F (0°C) to 194°F (90°C)
- Operating pressure: Max. 142 psi
- Inlet pressure: Max 85 psi

#### Suitable Liquids:

- Clean or other non-corrosive liquids







### PRO-LINE®

Diaphragm Well Tanks: PL Series

125 PSIG Working Pressure

#### Construction

Shell	Deep Drawn Steel
Diaphragm	Butyl
Liner	Polypropylene
System Connection	304L Stainless Steel
Finish	Tan
Water Circulator	Turbulator™
Air Valve	Projection Welded
Factory Precharge	38 PSIG (2.6 bar)

#### Application

- Controls pump cycling in residential well water systems.

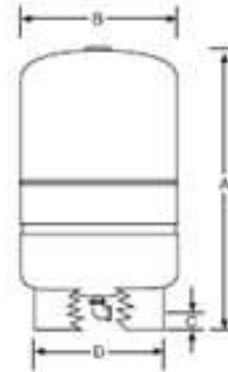

#### Performance

Maximum Operating Temperature	200°F (93°C)
Maximum Working Pressure	125 PSIG (8.6 bar)
Maximum Relief Valve Setting	100 PSIG (6.9 bar)
Warranty	5 Year

#### Stand Models

Model	Tank Volume		Max. Accel. Factor	A Tank Height		B Tank Diameter		C Sys. Conn. Centerline		D Stand Diameter		System Conn. (NPT)	Shipping Weight	
	Gal.	Lit.		in.	mm.	in.	mm.	in.	mm.	in.	mm.		Lbs.	Kg.
PL-14	14.0	53	0.81	25	635	15	381	1 1/4	40	12	304	1	22	10
PL-20	20.0	76	0.67	32	813	18	381	1 1/4	40	12	304	1	28	13
PL-26	26.0	98	0.44	39	991	15	381	1 1/4	40	12	304	1	34	15
PL-32	32.0	121	0.35	47	1194	15	381	1 1/4	40	12	304	1	40	18
PL-34	34.0	129	1.00	30	762	22	559	1 1/4	49	20 1/2	521	1 1/4	50	23
PL-44	44.0	167	0.77	38	914	22	559	1 1/4	49	20 1/2	521	1 1/4	57	26
PL-62	62.0	235	0.55	47	1194	22	559	1 1/4	49	20 1/2	521	1 1/4	75	34
PL-81	81.0	301	0.41	57	1448	22	559	1 1/4	49	20 1/2	521	1 1/4	92	42
PL-86	86.0	325	0.54	47	1194	26	660	2 1/4	52	20 1/2	521	1 1/4	99	45
PL-119	119.0	450	0.39	62	1575	26	660	2 1/4	52	20 1/2	521	1 1/4	133	60

All dimensions and weights are approximate.