

BOESCH

www.BoeschPumps.com

Oil Sentinel[®]

OIL SENTINEL BT300 SERIES

60HZ-ANSI

**2" FULL FREE PASSAGE SUBMERSIBLE
SEWAGE PUMP**



BOESCH PUMPS LLC

Art Chibli
achibli@boeschpumps.com

14031 SW 143rd Court Miami, FL 33186 (305) 999-1769 & (786) 310-6988

MOTOR / PUMP SPECIFICATIONS

ITEM		DESCRIPTION
LIMITS	Liquid Temp	0~40°C
	Application	Commercial / Industrial / Municipal use
TYPE	Frequency	60Hz
	Motor	2P (3450RPM) Dry Motor
	Insulation	Class B
	Start Method	Direct On Line
	Protection	IP 68
	Protector	Auto-Cut
	Bearing	Ball Type
	Mech. Seal	Dual. Mechanical Seal
	Impeller	Vortex Impeller
	MATERIAL	Motor Cover
Motor Housing+Stator		AISI 316
Shaft with Rotor		AISI 316
Mech. Seal		Upper: CA/CE; Lower: SIC/SIC
Pump Casing		AISI 316
Impeller		AISI 316
Cable		H07RN-F / SJTOW / STOW



MOTOR / PUMP DATA CHART

MODEL	OUTPUT		DISCHARGE INCHES	PHASE VOLTAGE	1Ø			FREE PASSAGE	WEIGHT W/O CABLE
	HP	KW			115V	208V	230V	INCHES	LBS
BT50/1	0.5	0.37	2	FULL LOAD AMPS	8A	4.4A	4A	1.4	29
BT100/1	1	0.75	2		12A	6.6A	6A	1.4	35
BT200/1	2	1.5	2 (3)		-	12.2A	11A	1.8	69
BT300/1	3	2.2	2 (3)		-	12.2A	11A	1.8	72

MODEL	OUTPUT		DISCHARGE INCHES	PHASE VOLTAGE	3Ø			FREE PASSAGE	WEIGHT W/O CABLE
	HP	KW			208V	230V	460V	INCHES	LBS
BT50/3	0.5	0.37	2	FULL LOAD AMPS	3.1A	2.8A	1.4A	1.4	28
BT100/3	1	0.75	2		4.4A	4A	2A	1.4	35
BT200/3	2	1.5	2 (3)		7.7A	7A	3.5A	1.8	65
BT300/3	3	2.2	2 (3)		8.8A	8A	4.5A	1.8	69
BT500/3	4	3.7	3 (4)		16.6A	15A	8A	1.8	106
BT750/3	5	5.5	3 (4)		23.2A	21A	10.5A	1.8	119

MOTOR / PUMP CONSTRUCTION MATERIAL

PART	MATERIAL	PART	MATERIAL
Cable	H07RN-F/STJOW/STOW	Mechanical Seal	Upper: CA / CE
Handle	Nylon 6(0.5-1HP) AISI 316 (2-7.5HP)	Mechanical Seal	Lower: SIC / SIC
Motor Cover	AISI 316	Seal Housing	AISI 316
Bracket	ASTM A48 Class 30	Lip Seal	VITON
Motor Housing + Stator	AISI 316	Impeller	AISI 316
Shaft with Rotor	AISI 316	Pump Casing	AISI 316
Oil Chamber	ASTM A48 Class 30(0.5-1HP) AISI 316(2-7.5HP)	Upper/Lower Bearing	NTN/TPI

PUMP PERFORMANCE REPORT

MODEL	BT300		HEAD	RATED
FREQUENCY	60 HZ		45 ft / 13.7 m	
DISCHARGE	2 & 3 inches / 50 & 80 mm		CAPACITY	100 gpm / 378 lpm
OUTPUT	3 hp / 2.2 kW		POLE / RPM	2 poles / 3450 rpm

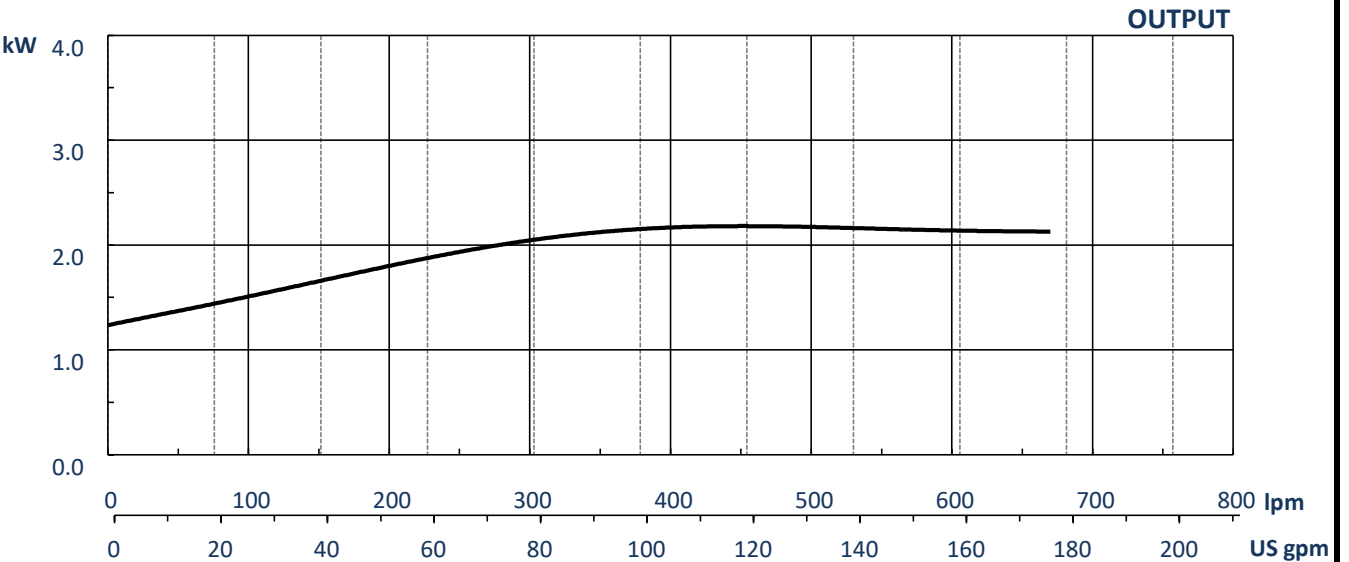
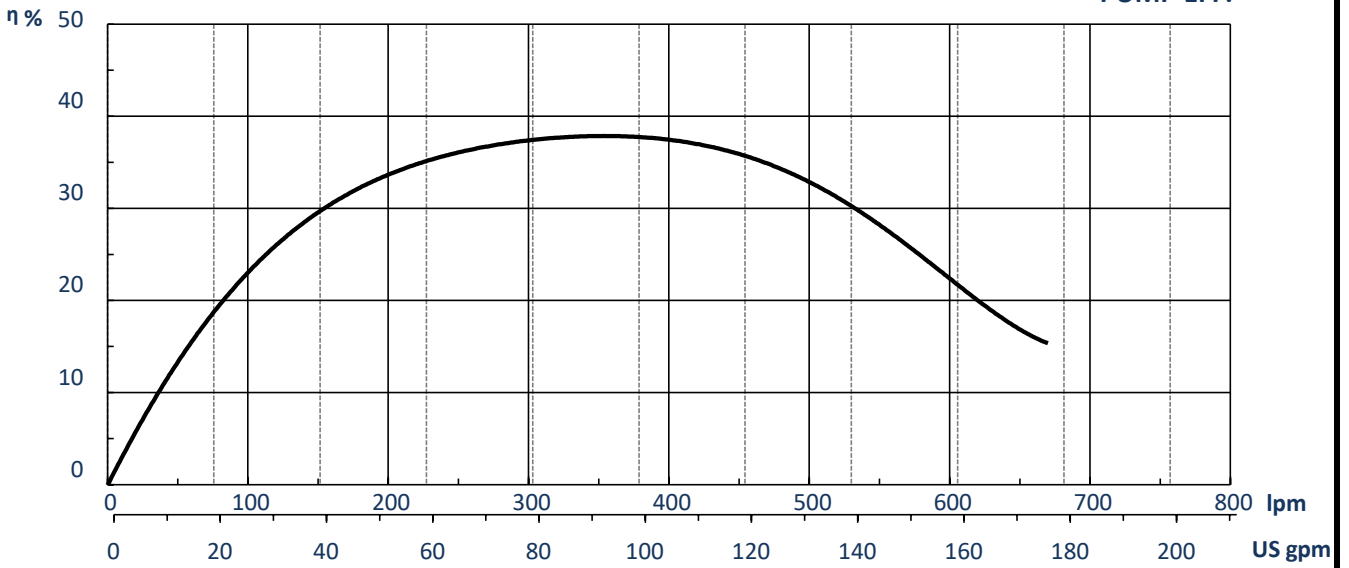
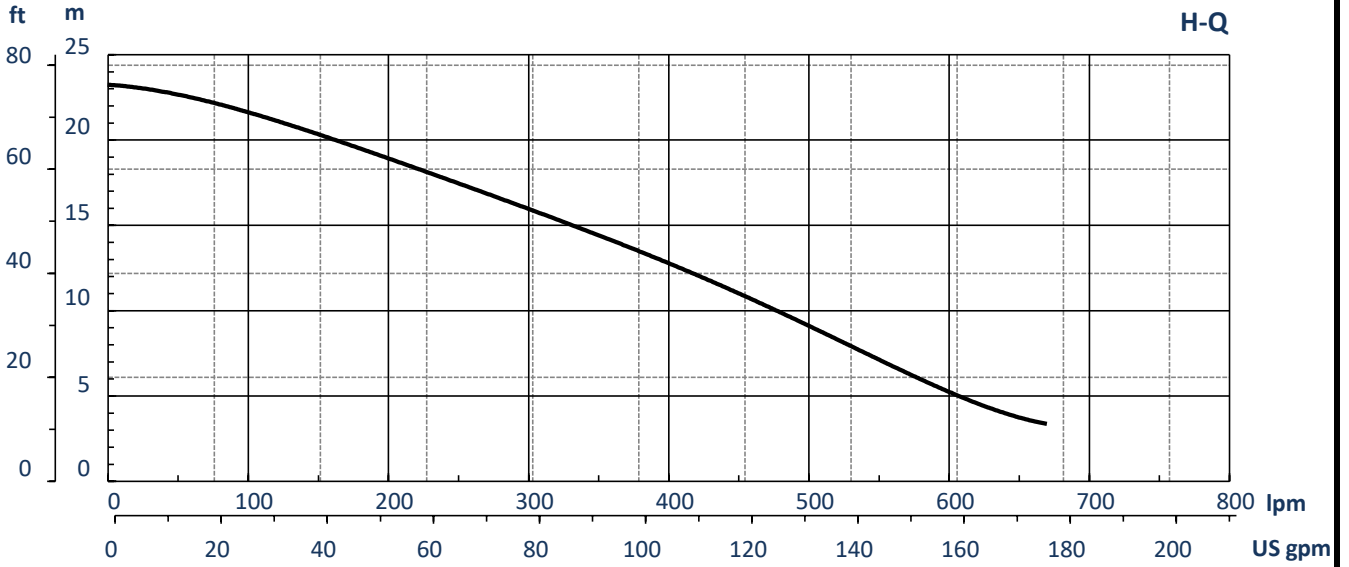

DIMENSIONAL DRAWING

MODELS: BT200 – BT300 (2~3HP)

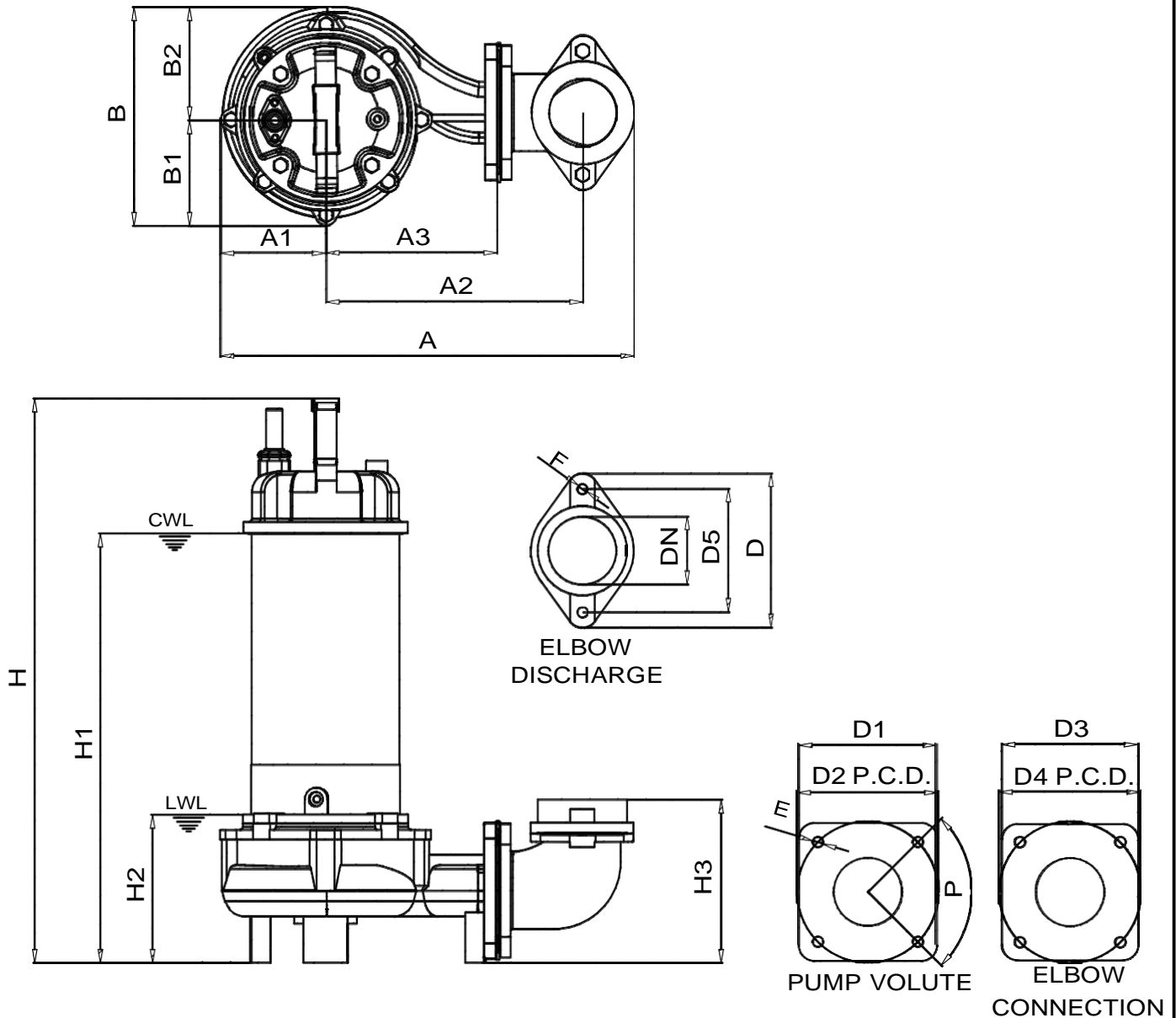

MODEL	A	A1	A2	A3	B	B1	B2	D	D1	D2	D3
BT200	15.35	4.06	9.25	6.06	8.19	4.09	4.09	5.91	5.20	5.31	5.12
BT300	15.35	4.06	9.25	6.06	8.19	4.09	4.09	5.91	5.20	5.31	5.12

MODEL	D4	D5	DN	E	F	P	H	H1	H2	H3	WT	
BT200	5.31	4.72	2 / 3	.39	.39	90	20.94	15.75	5.91	5.98	S: 69	T: 65
BT300	5.31	4.72	2 / 3	.39	.39	90	20.52	17.32	5.91	5.98	S: 72	T: 69

CWL: CONTINUOUS RUNNING WATER LEVEL
 LWL: LOWEST RUNNING WATER LEVEL
 WT: WEIGHT WITHOUT CABLE
 S: SINGLE PHASE T: THREE PHASE

DIMENSIONS: INCHES
 WEIGHT: LBS
 PIPE CONNECTION TYPE: NPT

The Boesch Oil Sentinel is used in elevator sump pits to remove water while retaining oil and other hydrocarbons.

KEY FEATURES

ONE SENSOR

One preset level sensor for easy installation.

REMOTE ALARM

A remote alarm is included with the Oil Sentinel. Includes auxiliary contacts for High Oil, High Water and Pump Overload (on overload models).

MULTIPLE INDICATOR LIGHTS

Power On, Pump Run, High Water, High Oil and Pump Overload (on overload models).

ASME A17.1 COMPLIANT

WORKS WITH AUTO DIALERS OR BAS

(Building Automation Systems)



Control Panel



Remote Alarm



Preset Level Sensor

OPERATION OF DISCHARGE

Water and oil fill the elevator sump pit. As the sump is filling, the oil will float on top of the water. This layer of oil will not be pumped from the tank. The water underneath the oil will be pumped out through the discharge pipe to the sewer or other proper disposal area.

1. WATER RISES & PUMP TURNS ON

When the water reaches probe (#2) the system will turn on and pump the water out of the sump.

2. WATER IS REMOVED/OIL CONTAINED

As the water is being pumped from the sump pit, the oil will remain floating on top of the water. **THE OIL WILL NOT BE PUMPED INTO THE SANITARY SEWER**

3. PUMP TURNS OFF

When the water is pumped below probe (#1) the pump will turn off.

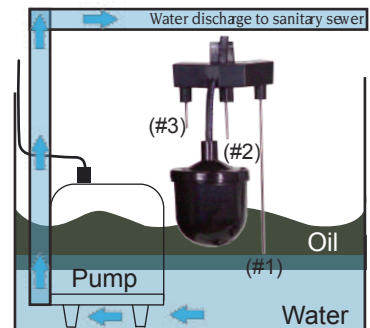
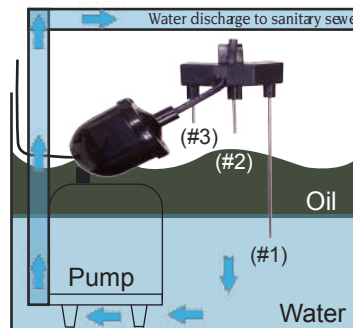
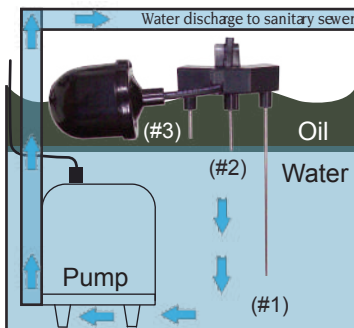

PRESET LEVEL SENSOR AND CONTROL PANEL OPERATION

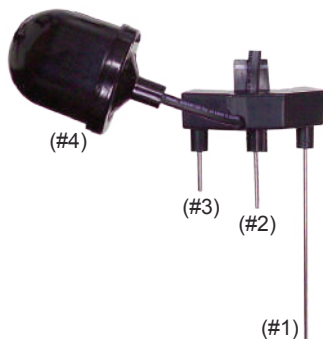

- ▶ When water touches probes (#1) and (#2) the pump will turn on.
- ▶ If the pump can not keep up, loses power or fails the water will reach probe (#3). The "High Water" light will illuminate on the control panel and the remote alarm will activate.
- ▶ If the water continues to rise the float switch will activate. If the float switch is activated and probe (#3) is touching water the "High Water" alarm will remain on. If OIL is touching probe (#3) and the float switch is activated, the "High Oil" light will illuminate and the remote alarm will activate.

DESCRIPTION OF OPERATION

On liquid rise, level reaches pump “Start” probe to start the pump. The pump will remain on until level is below “Off” probe. The “Off” probe senses air or oil and turns the pump off so the oil layer will not be pumped out of the tank. If the level reaches high level probe and high level float, the system will differentiate between water and oil and activate the remote alarm.

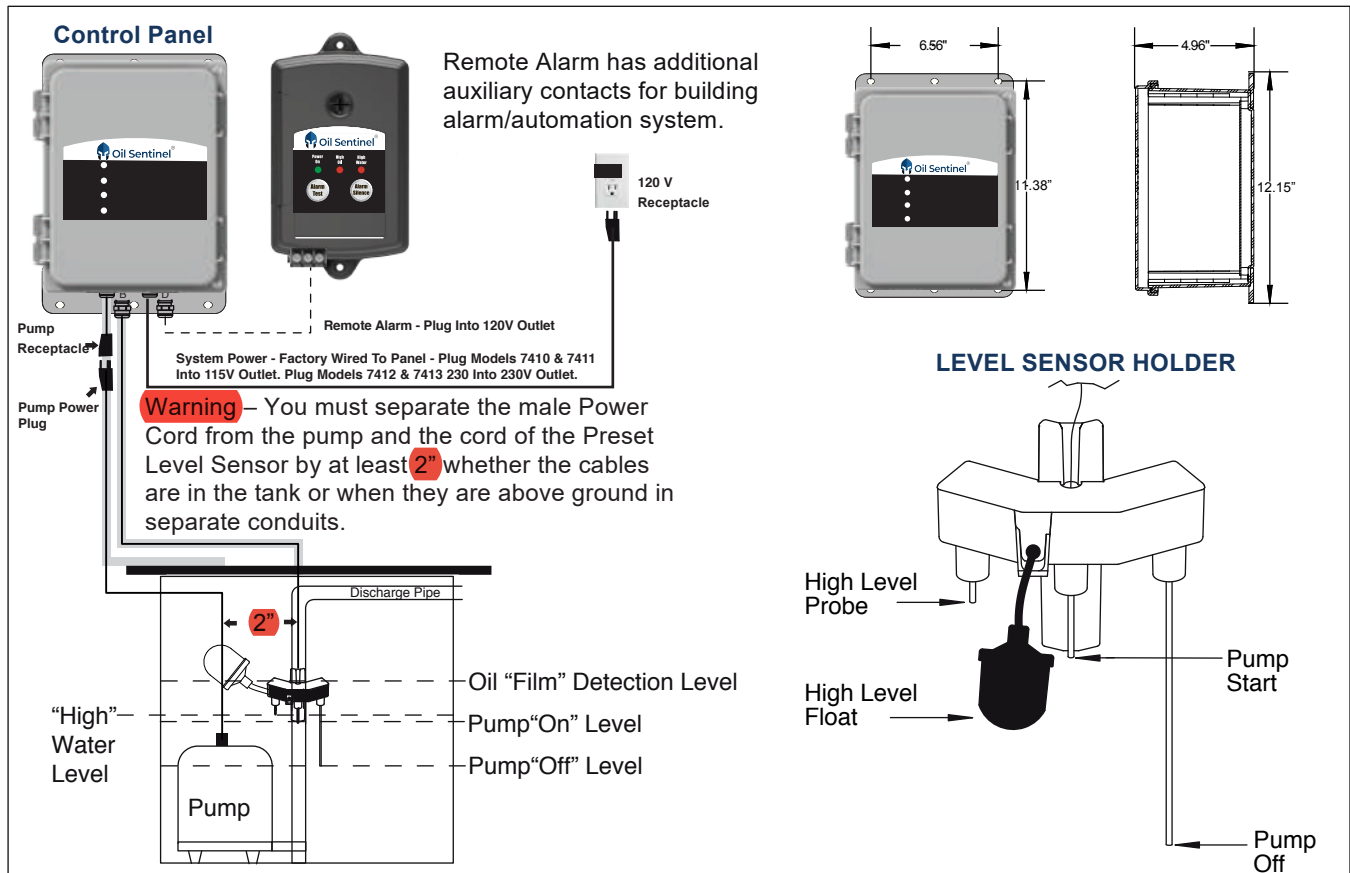

SPECIFICATIONS

Sensor

- ▶ Housing: ABS
- ▶ Probe: Stainless Steel
- ▶ Float: PVC

Control Panel

- ▶ Enclosure: Type 1
- ▶ Power Cord: 6' SJT, 120 VAC
- ▶ Receptacle: 6" SJT, 120 VAC, 15 Amp

Alarm Panel

- ▶ Enclosure: Type 1
- ▶ Power Cord: Plug in transformer, 120 VAC
- ▶ Backup Power: 9 VDC battery backup
- ▶ LED Alarm Indicators
- ▶ Audible Alarm: 103 db buzzer, auto/test rest
- ▶ Auxiliary Contact: High Water, High Oil, Optional Pump Fail



Oil Sentinel®

OIL CONTROL

OIL ALARM

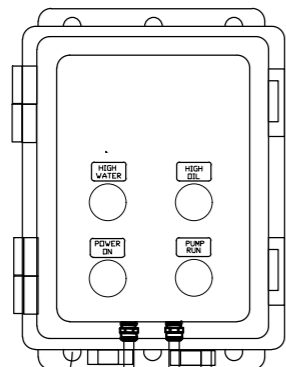
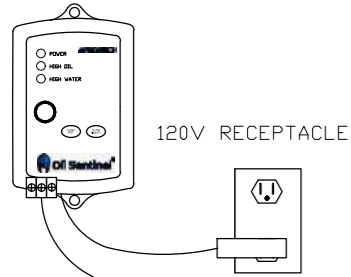

120/208/230/460

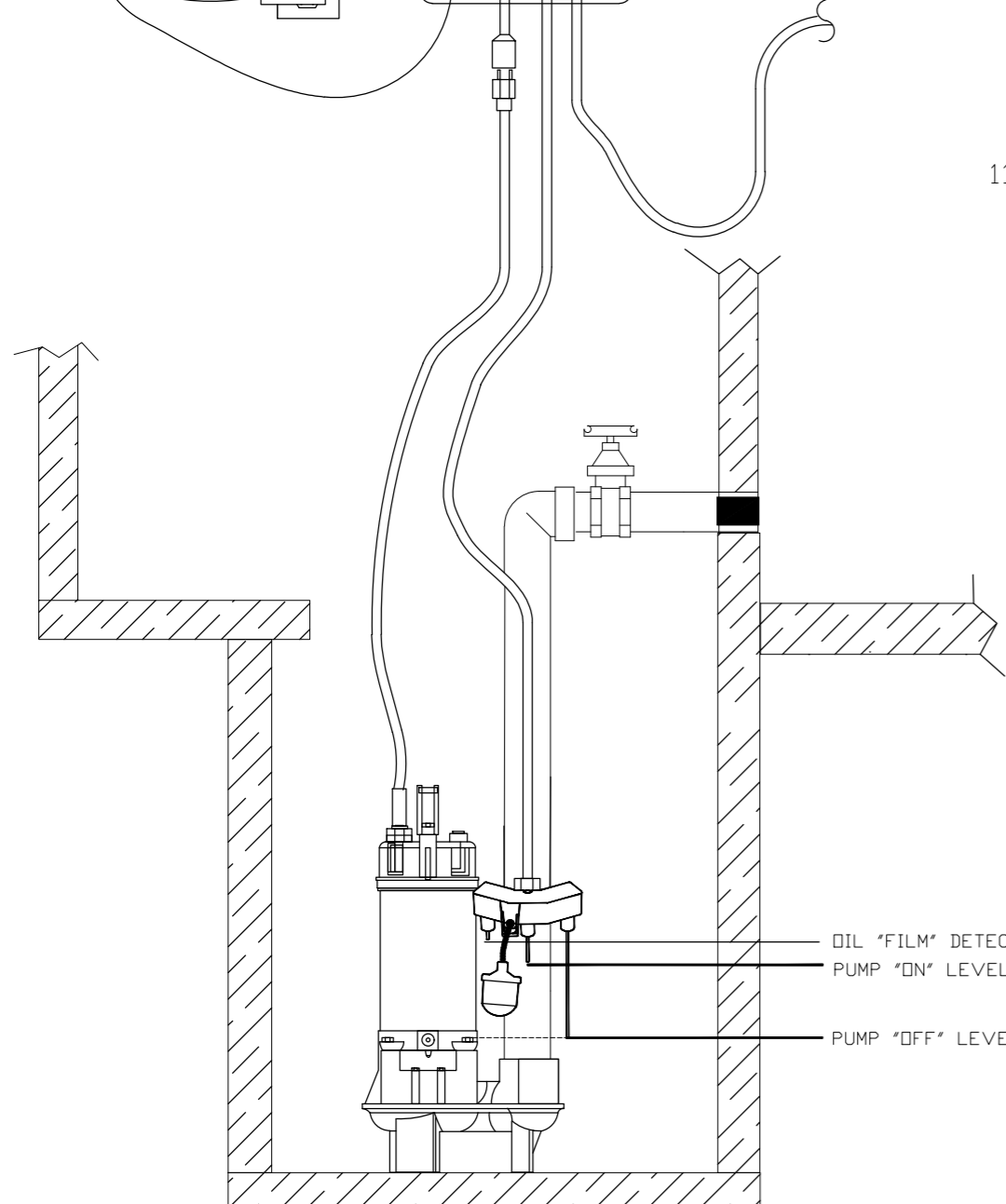

OIL CONTROL DIMENSIONS

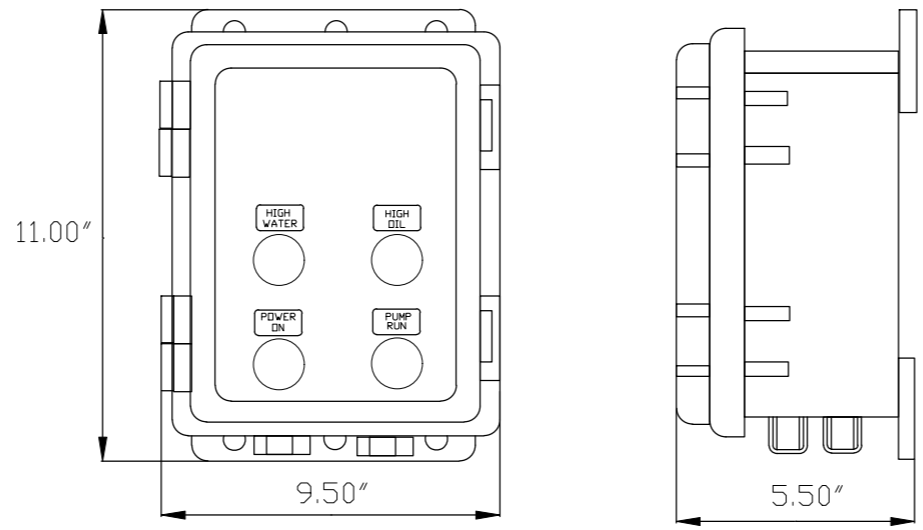

PUMP TOP VIEW

DIA 18.00"
DIA 11.00"

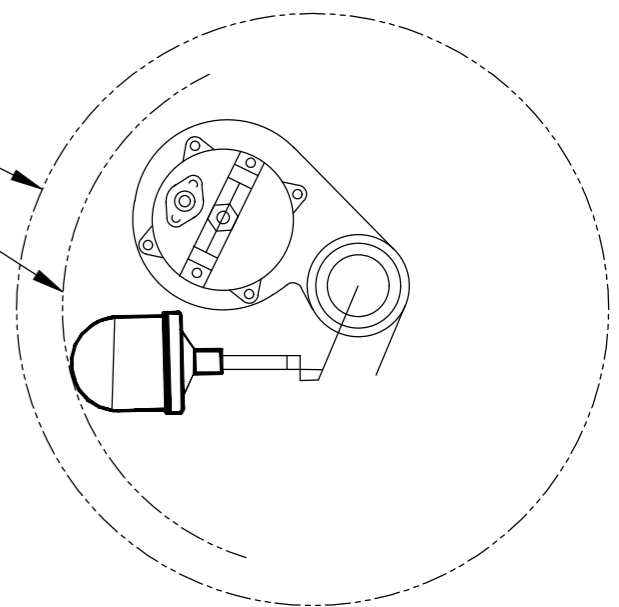

LEVEL SENSOR HOLDER

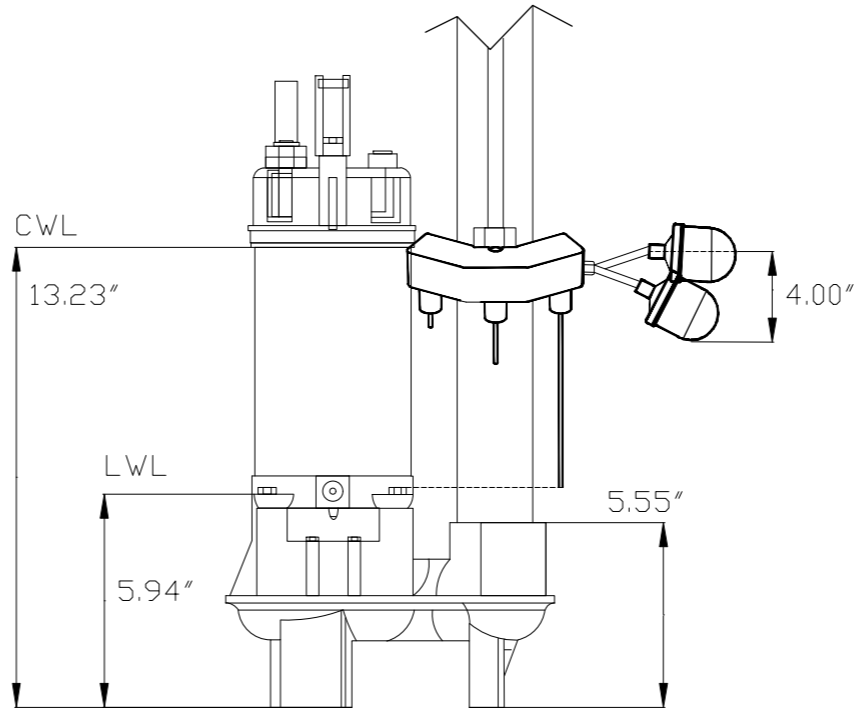
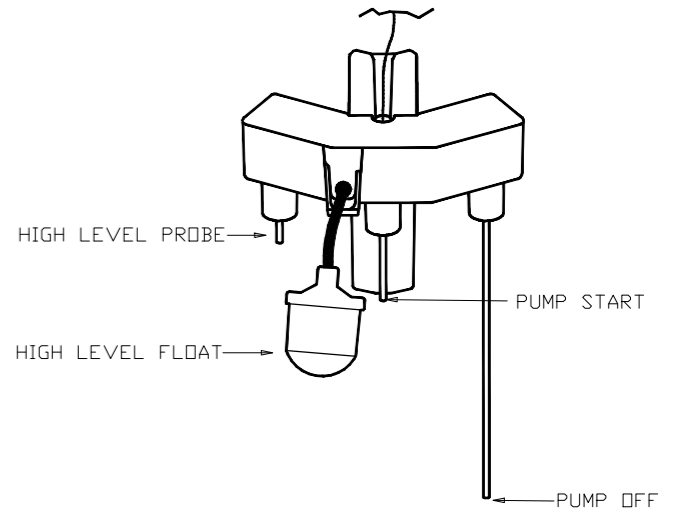

OIL "FILM" DETECTION LEVEL
PUMP "ON" LEVEL
PUMP "OFF" LEVEL



BOESCH PUMPS LLC
Art Chibli
(305) 999-1769
achibli@boeschpumps.com
BoeschPumps.com

BOESCH OIL SENTINEL

Revision notes:		
Rev:	Date:	Notes:
A	06/15/21	PROJECT

Drawn by: C.Grajeda	Client:
-------------------------------	----------------

Project: BOESCH	Drawing Title: OIL SENTINEL
---------------------------	---------------------------------------

Date: 06/14/2021	Revision: A
Scale @ A3: XXXX	