

**BOESCH**

[www.BoeschPumps.com](http://www.BoeschPumps.com)

**Oil Sentinel<sup>®</sup>**

# OIL SENTINEL BT50 SERIES

**60HZ-ANSI**

**2" FULL FREE PASSAGE SUBMERSIBLE  
SEWAGE PUMP**



**BOESCH PUMPS LLC**

Art Chibli  
[achibli@boeschpumps.com](mailto:achibli@boeschpumps.com)

14031 SW 143rd Court Miami, FL 33186 (305) 999-1769 & (786) 310-6988

### MOTOR / PUMP SPECIFICATIONS

|                      | ITEM         | DESCRIPTION                             |
|----------------------|--------------|-----------------------------------------|
| LIMITS               | Liquid Temp  | 0~40°C                                  |
|                      | Application  | Commercial / Industrial / Municipal use |
| TYPE                 | Frequency    | 60Hz                                    |
|                      | Motor        | 2P (3450RPM) Dry Motor                  |
|                      | Insulation   | Class B                                 |
|                      | Start Method | Direct On Line                          |
|                      | Protection   | IP 68                                   |
|                      | Protector    | Auto-Cut                                |
|                      | Bearing      | Ball Type                               |
|                      | Mech. Seal   | Dual. Mechanical Seal                   |
|                      | Impeller     | Vortex Impeller                         |
|                      | MATERIAL     | Motor Cover                             |
| Motor Housing+Stator |              | AISI 316                                |
| Shaft with Rotor     |              | AISI 316                                |
| Mech. Seal           |              | Upper: CA/CE; Lower: SIC/SIC            |
| Pump Casing          |              | AISI 316                                |
| Impeller             |              | AISI 316                                |
| Cable                |              | H07RN-F / SJTOW / STOW                  |



### MOTOR / PUMP DATA CHART

| MODEL   | OUTPUT |      | DISCHARGE | PHASE          | 1Ø   |       |      | FREE PASSAGE | WEIGHT W/O CABLE |
|---------|--------|------|-----------|----------------|------|-------|------|--------------|------------------|
|         | HP     | KW   | INCHES    | VOLTAGE        | 115V | 208V  | 230V | INCHES       | LBS              |
| BT50/1  | 0.5    | 0.37 | 2         | FULL LOAD AMPS | 8A   | 4.4A  | 4A   | 1.4          | 29               |
| BT100/1 | 1      | 0.75 | 2         |                | 12A  | 6.6A  | 6A   | 1.4          | 35               |
| BT200/1 | 2      | 1.5  | 2 ( 3 )   |                | -    | 12.2A | 11A  | 1.8          | 69               |
| BT300/1 | 3      | 2.2  | 2 ( 3 )   |                | -    | 12.2A | 11A  | 1.8          | 72               |

| MODEL   | OUTPUT |      | DISCHARGE | PHASE          | 3Ø    |      |       | FREE PASSAGE | WEIGHT W/O CABLE |
|---------|--------|------|-----------|----------------|-------|------|-------|--------------|------------------|
|         | HP     | KW   | INCHES    | VOLTAGE        | 208V  | 230V | 460V  | INCHES       | LBS              |
| BT50/3  | 0.5    | 0.37 | 2         | FULL LOAD AMPS | 3.1A  | 2.8A | 1.4A  | 1.4          | 28               |
| BT100/3 | 1      | 0.75 | 2         |                | 4.4A  | 4A   | 2A    | 1.4          | 35               |
| BT200/3 | 2      | 1.5  | 2 ( 3 )   |                | 7.7A  | 7A   | 3.5A  | 1.8          | 65               |
| BT300/3 | 3      | 2.2  | 2 ( 3 )   |                | 8.8A  | 8A   | 4.5A  | 1.8          | 69               |
| BT500/3 | 4      | 3.7  | 3 ( 4 )   |                | 16.6A | 15A  | 8A    | 1.8          | 106              |
| BT750/3 | 5      | 5.5  | 3 ( 4 )   |                | 23.2A | 21A  | 10.5A | 1.8          | 119              |

### MOTOR / PUMP CONSTRUCTION MATERIAL

| PART                   | MATERIAL                                        | PART                | MATERIAL         |
|------------------------|-------------------------------------------------|---------------------|------------------|
| Cable                  | H07RN-F/STJOW/STOW                              | Mechanical Seal     | Upper: CA / CE   |
| Handle                 | Nylon 6(0.5-1HP)<br>AISI 316 (2-7.5HP)          | Mechanical Seal     | Lower: SIC / SIC |
| Motor Cover            | AISI 316                                        | Seal Housing        | AISI 316         |
| Bracket                | ASTM A48 Class 30                               | Lip Seal            | VITON            |
| Motor Housing + Stator | AISI 316                                        | Impeller            | AISI 316         |
| Shaft with Rotor       | AISI 316                                        | Pump Casing         | AISI 316         |
| Oil Chamber            | ASTM A48 Class 30(0.5-1HP)<br>AISI 316(2-7.5HP) | Upper/Lower Bearing | NTN/TPI          |

## PUMP PERFORMANCE REPORT

|           |                  |  |                    |
|-----------|------------------|--|--------------------|
| MODEL     | BT50             |  | RATED              |
| FREQUENCY | 60 HZ            |  | HEAD               |
| DISCHARGE | 2 inches / 50 mm |  | CAPACITY           |
| OUTPUT    | 0.5 hp / 0.37 kW |  | POLE / RPM         |
|           |                  |  | 22 ft / 6.7 m      |
|           |                  |  | 50 gpm / 189 lpm   |
|           |                  |  | 2 poles / 3450 rpm |

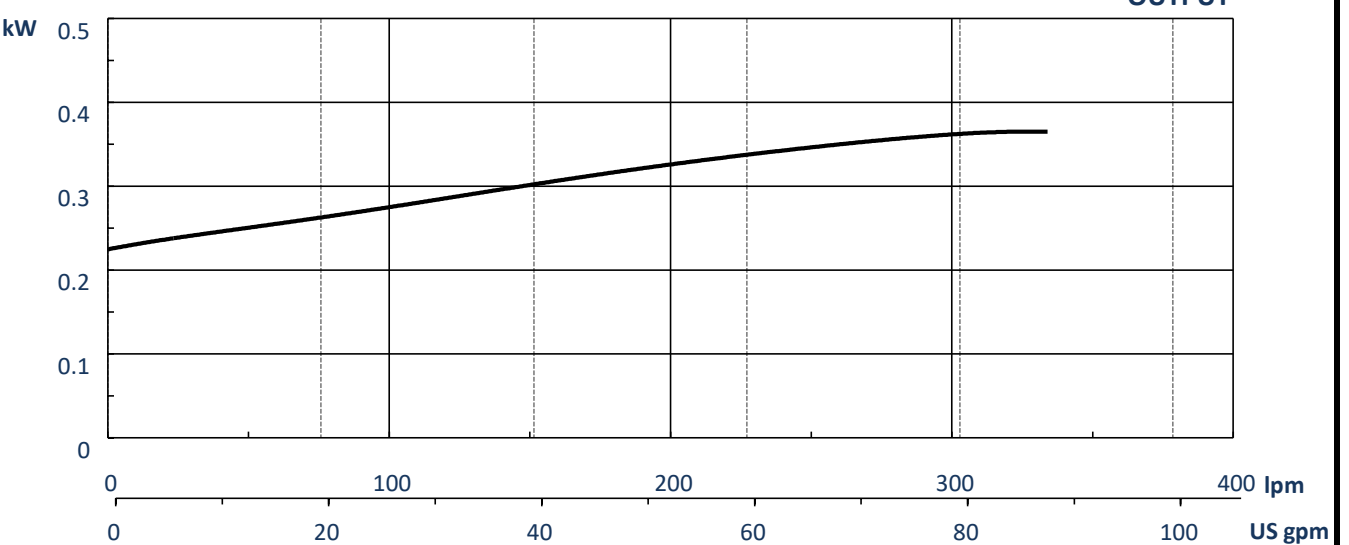
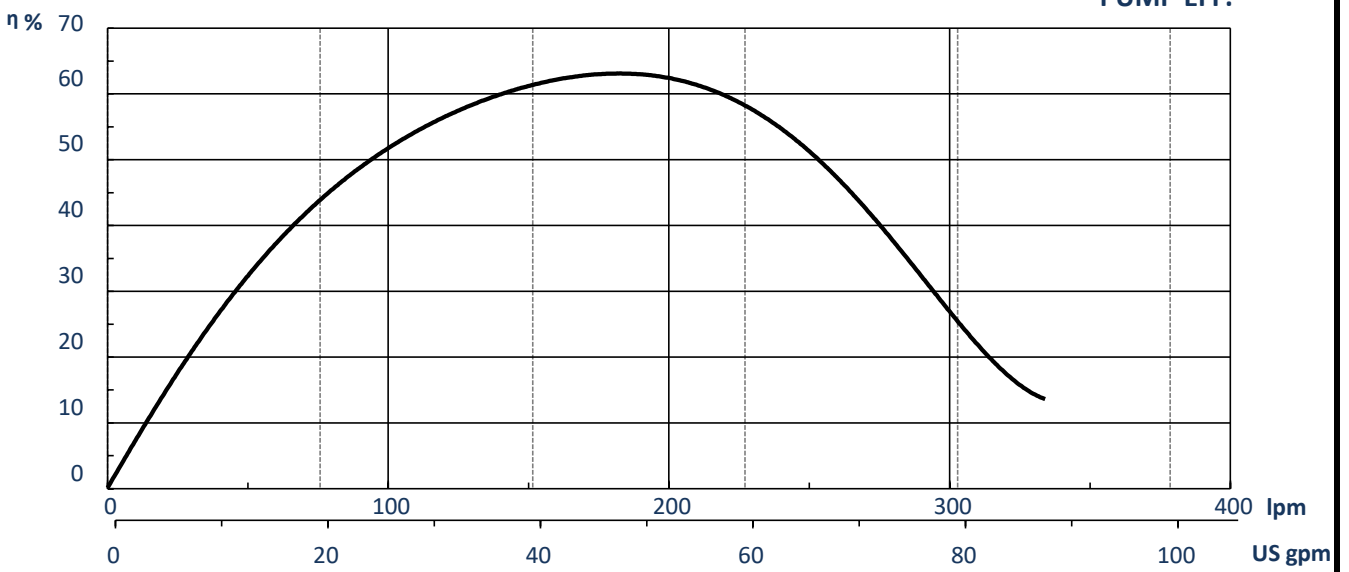
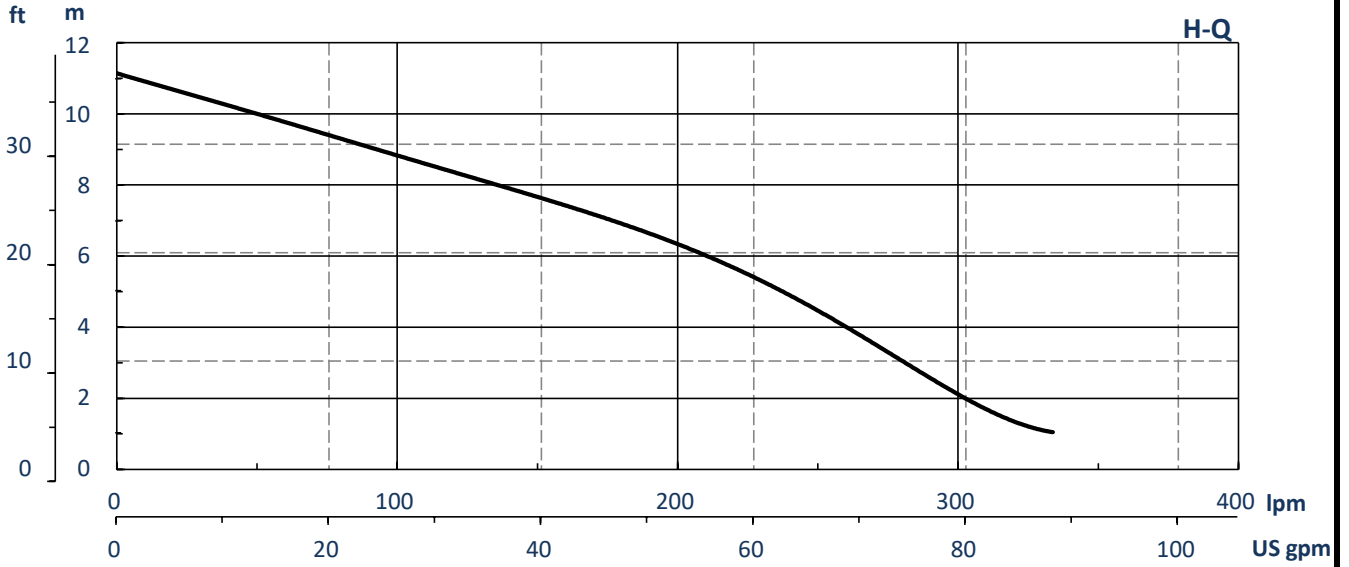

### DIMENSIONAL DRAWING

MODELS: BT50 – BT100 (0.5~1HP)

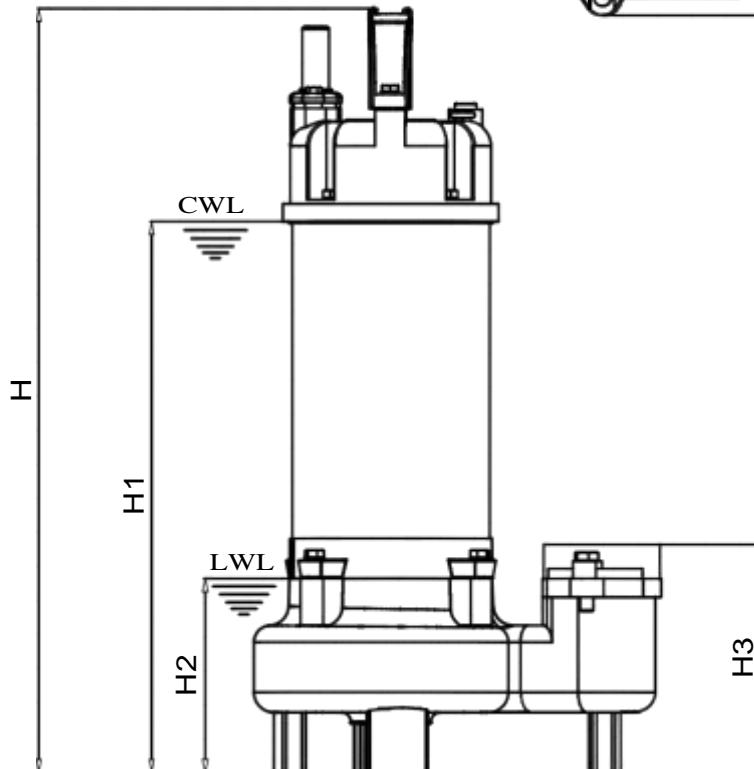
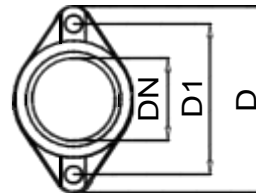
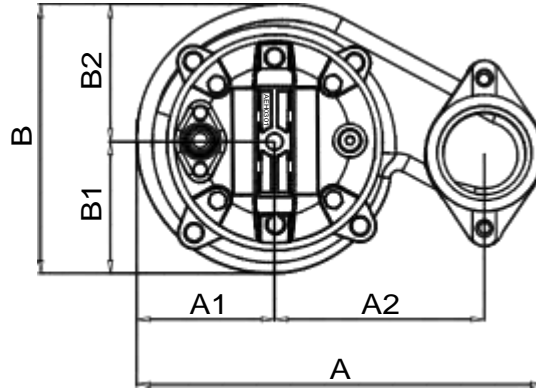

| MODEL | A    | A1   | A2   | B    | B1   | B2   | D    | D1   | DN | H     | H1    | H2   | H3   | WT     |        |
|-------|------|------|------|------|------|------|------|------|----|-------|-------|------|------|--------|--------|
| BT50  | 8.98 | 2.95 | 4.72 | 5.91 | 2.76 | 3.15 | 4.33 | 3.54 | 2  | 16.73 | 11.69 | 4.61 | 5.43 | S:28.6 | T:27.3 |
| BT100 | 8.98 | 2.95 | 4.72 | 5.91 | 2.76 | 3.15 | 4.33 | 3.54 | 2  | 16.91 | 12.87 | 4.61 | 5.43 | S:33.9 | T:34.5 |

CWL: CONTINUOUS RUNNING WATER LEVEL  
 LWL: LOWEST RUNNING WATER LEVEL  
 WT: WEIGHT WITHOUT CABLE  
 S: SINGLE PHASE      T: THREE PHASE

DIMENSIONS: INCHES  
 WEIGHT: LBS  
 PIPE CONNECTION TYPE: NPT

The Boesch Oil Sentinel is used in elevator sump pits to remove water while retaining oil and other hydrocarbons.

## KEY FEATURES

### ONE SENSOR

One preset level sensor for easy installation.

### REMOTE ALARM

A remote alarm is included with the Oil Sentinel. Includes auxiliary contacts for High Oil, High Water and Pump Overload (on overload models).

### MULTIPLE INDICATOR LIGHTS

Power On, Pump Run, High Water, High Oil and Pump Overload (on overload models).

### ASME A17.1 COMPLIANT

WORKS WITH AUTO DIALERS OR BAS

(Building Automation Systems)



Control Panel



Remote Alarm



Preset Level Sensor

## OPERATION OF DISCHARGE

Water and oil fill the elevator sump pit. As the sump is filling, the oil will float on top of the water. This layer of oil will not be pumped from the tank. The water underneath the oil will be pumped out through the discharge pipe to the sewer or other proper disposal area.

### 1. WATER RISES & PUMP TURNS ON

When the water reaches probe (#2) the system will turn on and pump the water out of the sump.

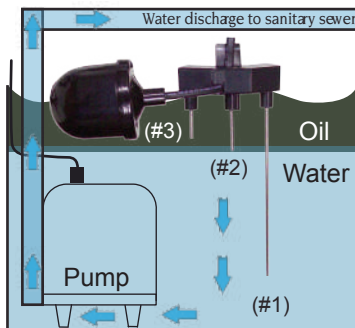

### 2. WATER IS REMOVED/OIL CONTAINED

As the water is being pumped from the sump pit, the oil will remain floating on top of the water. **THE OIL WILL NOT BE PUMPED INTO THE SANITARY SEWER**

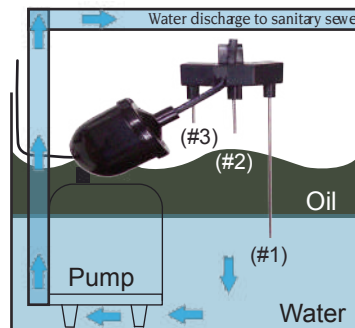

### 3. PUMP TURNS OFF

When the water is pumped below probe (#1) the pump will turn off.

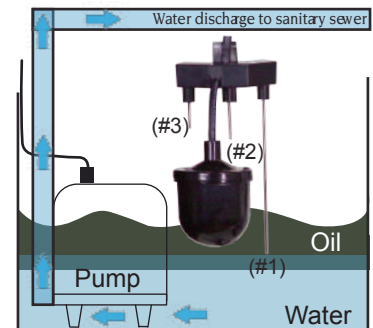

## PRESET LEVEL SENSOR AND CONTROL PANEL OPERATION

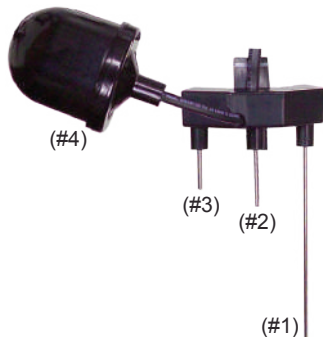

- ▶ When water touches probes (#1) and (#2) the pump will turn on.
- ▶ If the pump can not keep up, loses power or fails the water will reach probe (#3). The "High Water" light will illuminate on the control panel and the remote alarm will activate.
- ▶ If the water continues to rise the float switch will activate. If the float switch is activated and probe (#3) is touching water the "High Water" alarm will remain on. If OIL is touching probe (#3) and the float switch is activated, the "High Oil" light will illuminate and the remote alarm will activate.

## DESCRIPTION OF OPERATION

On liquid rise, level reaches pump “Start” probe to start the pump. The pump will remain on until level is below “Off” probe. The “Off” probe senses air or oil and turns the pump off so the oil layer will not be pumped out of the tank. If the level reaches high level probe and high level float, the system will differentiate between water and oil and activate the remote alarm.

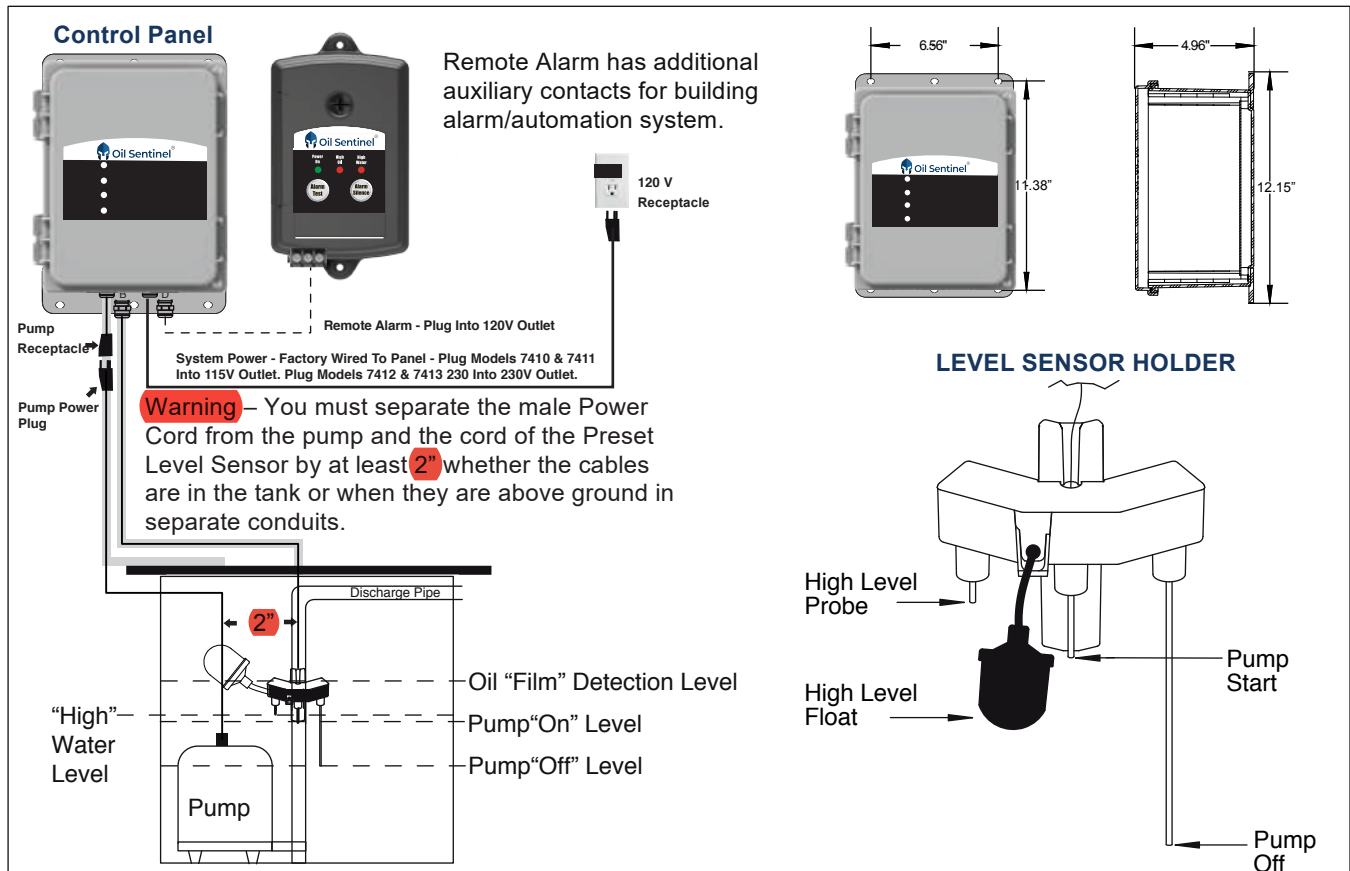

## SPECIFICATIONS

### Sensor

- ▶ Housing: ABS
- ▶ Probe: Stainless Steel
- ▶ Float: PVC

### Control Panel

- ▶ Enclosure: Type 1
- ▶ Power Cord: 6' SJT, 120 VAC
- ▶ Receptacle: 6" SJT, 120 VAC, 15 Amp

### Alarm Panel

- ▶ Enclosure: Type 1
- ▶ Power Cord: Plug in transformer, 120 VAC
- ▶ Backup Power: 9 VDC battery backup
- ▶ LED Alarm Indicators
- ▶ Audible Alarm: 103 db buzzer, auto/test rest
- ▶ Auxiliary Contact: High Water, High Oil, Optional Pump Fail



# Oil Sentinel®

OIL CONTROL

OIL ALARM

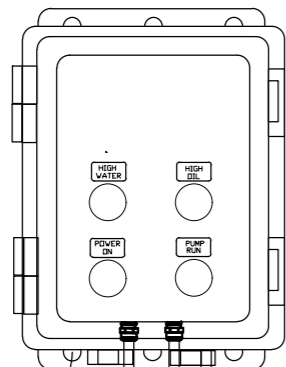
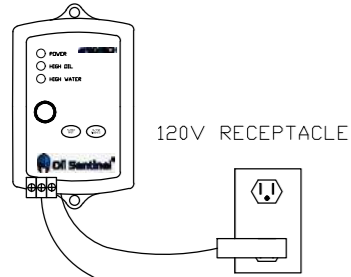

120/208/230/460

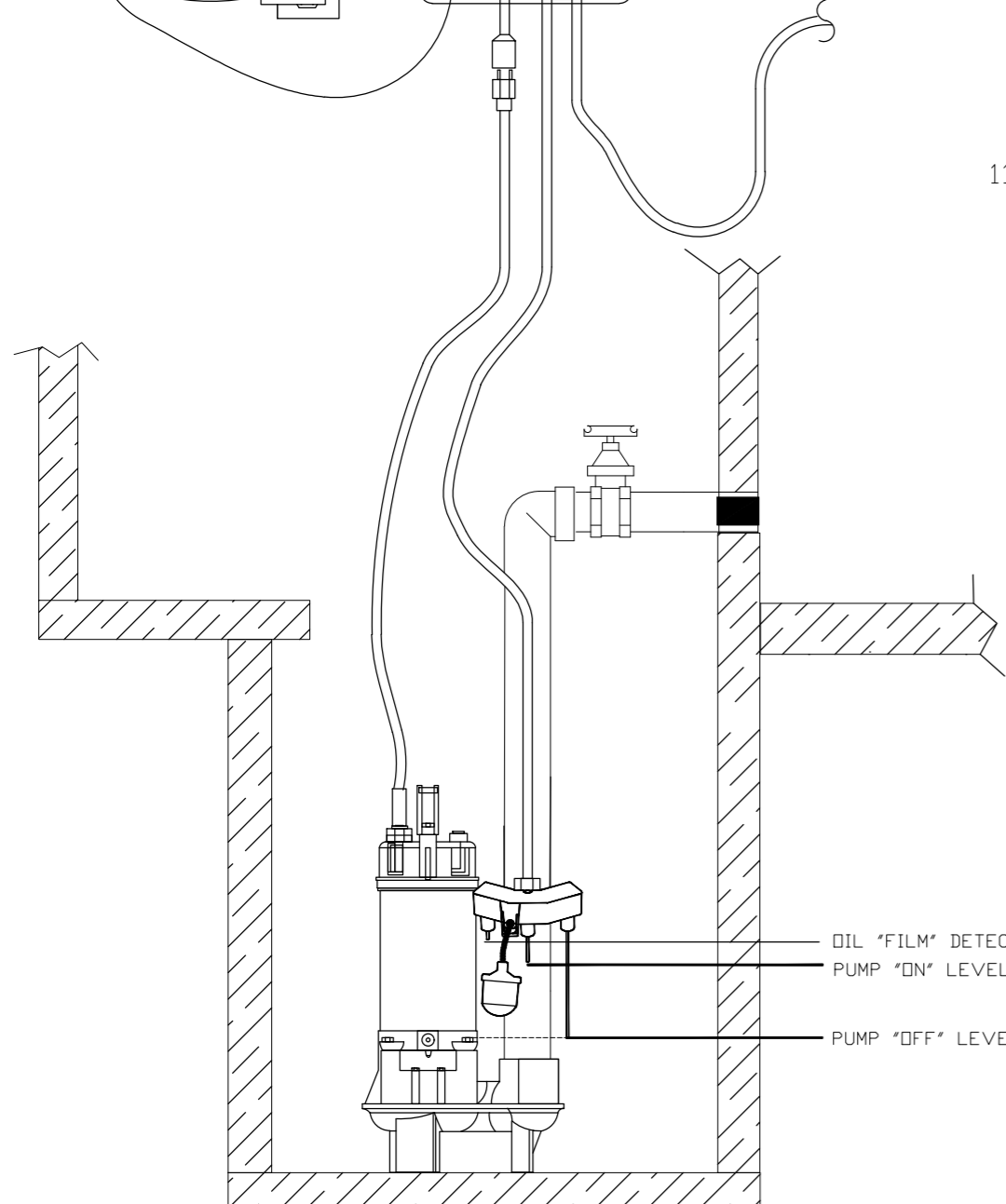

OIL CONTROL DIMENSIONS

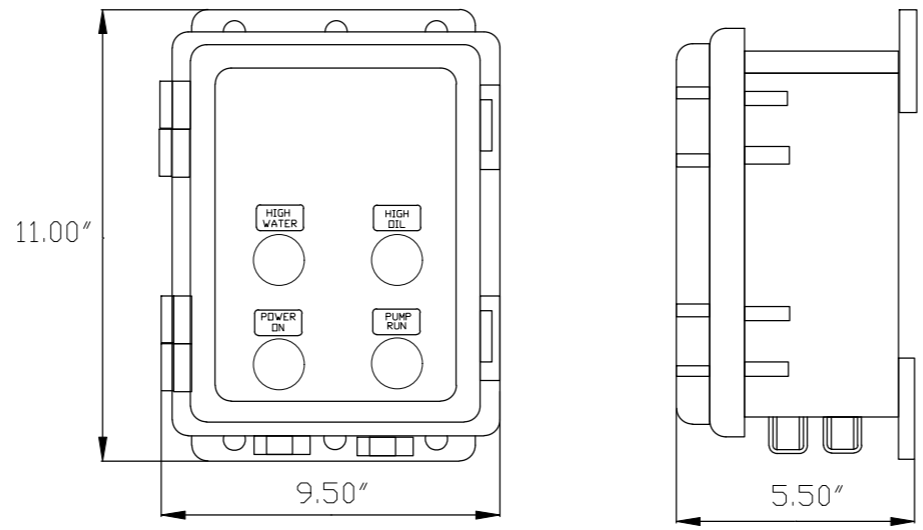

PUMP TOP VIEW

DIA 18.00"  
DIA 11.00"

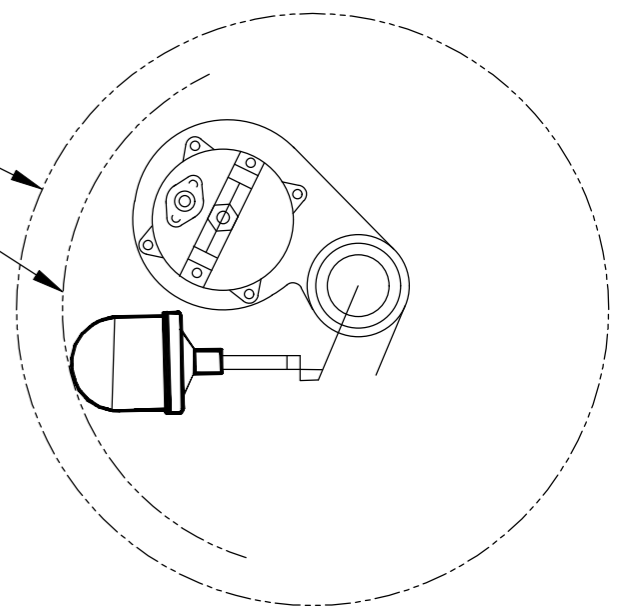

LEVEL SENSOR HOLDER

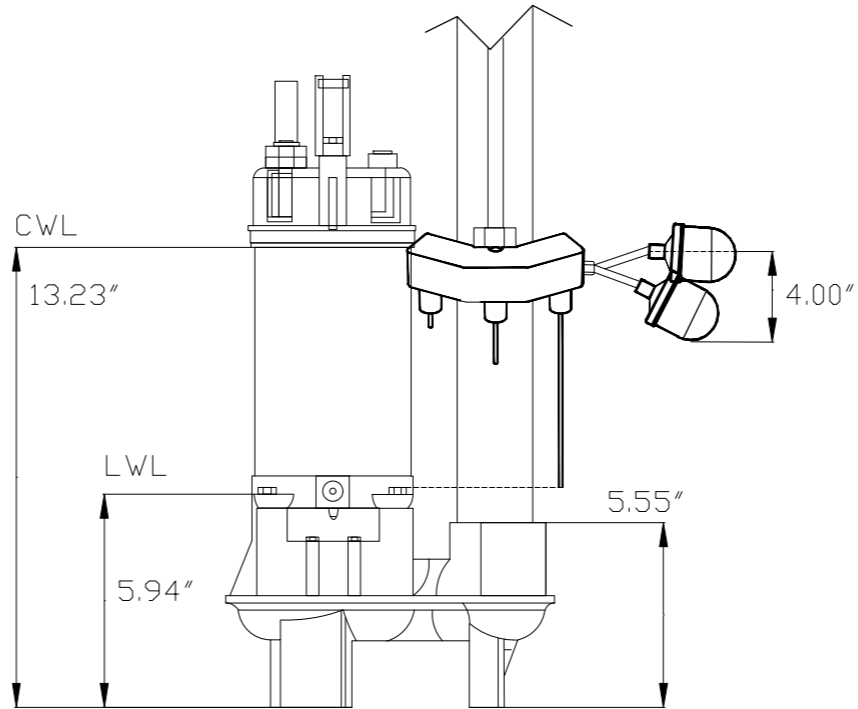
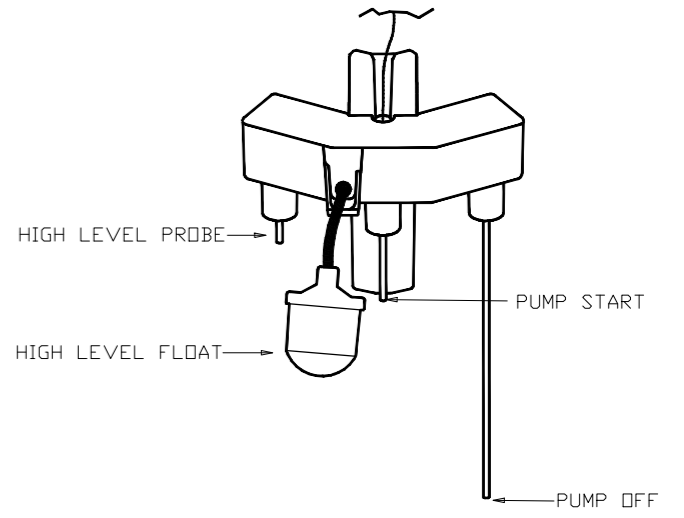

BOESCH PUMPS LLC  
Art Chibli  
(305) 999-1769  
achibli@boeschpumps.com  
BoeschPumps.com

BOESCH OIL SENTINEL

| Revision notes: |          |         |
|-----------------|----------|---------|
| Rev:            | Date:    | Notes:  |
| A               | 06/15/21 | PROJECT |

|                               |                |
|-------------------------------|----------------|
| <b>Drawn by:</b><br>C.Grajeda | <b>Client:</b> |
|-------------------------------|----------------|

|                           |                                       |
|---------------------------|---------------------------------------|
| <b>Project:</b><br>BOESCH | <b>Drawing Title:</b><br>OIL SENTINEL |
|---------------------------|---------------------------------------|

|                            |                       |
|----------------------------|-----------------------|
| <b>Date:</b><br>06/14/2021 | <b>Revision:</b><br>A |
| <b>Scale @ A3:</b><br>XXXX |                       |