

BOESCH

www.BoeschPumps.com



Traction Sentinel[®]

TRACTION SENTINEL BT300 SERIES

60HZ-ANSI

**2" FULL FREE PASSAGE SUBMERSIBLE
SEWAGE PUMP**



BOESCH PUMPS LLC
Art Chibli
achibli@boeschpumps.com

14031 SW 143rd Court Miami, FL 33186

(305) 999-1769

SOLUTION FOR ASME 17.1 REQUIREMENTS FOR TRACTION (ELECTRIC) ELEVATORS

Boesch Traction Sentinel simplifies the pumping solution while ensuring the correct components are specified to meet application and code requirements for traction (electric) elevators for ASME 17.1 Safety Standard.

This package approach, inspired by the industry's acceptance of the Boesch Oil Sentinel[®] in hydraulic elevators—maximizes operational efficiencies from specification to installation.

Designing a plug-and-play, application-specific answer to pumps and associated equipment in traction (electric) elevators has led to the following features:

- Boesch BC/BN series pumps, featuring a vortex impeller design, have become the standard for elevator applications.
- NEMA 4X control panel with HOA switch, pump run light and a dry contacts for remote monitoring connectivity
 - Three N.O. externally weighted floats (on, off and high water) are included.
 - Ability to further customize with control panel features, main disconnect and/or junction box with 8-pin connector



MOTOR / PUMP SPECIFICATIONS

	ITEM	DESCRIPTION
LIMITS	Liquid Temp	0-40°C
	Application	Commercial / Industrial / Municipal use
TYPE	Frequency	60Hz
	Motor	2P (3450RPM) Dry Motor
	Insulation	Class B
	Start Method	Direct On Line
	Protection	IP 68
	Protector	Auto-Cut
	Bearing	Ball Type
	Mech. Seal	Dual. Mechanical Seal
MATERIAL	Impeller	Vortex Impeller
	Motor Cover	AISI 316
	Motor Housing+Stator	AISI 316
	Shaft with Rotor	AISI 316
	Mech. Seal	Upper: CA/CE; Lower: SIC/SIC
	Pump Casing	AISI 316
	Impeller	AISI 316
Cable	H07RN-F / SJTOW / STOW	



MOTOR / PUMP DATA CHART

MODEL	OUTPUT		DISCHARGE INCHES	PHASE VOLTAGE	1Ø			FREE PASSAGE	WEIGHT W/O CABLE
	HP	KW			115V	208V	230V	INCHES	LBS
BT50/1	0.5	0.37	2	FULL LOAD AMPS	8A	4.4A	4A	1.4	29
BT100/1	1	0.75	2		12A	6.6A	6A	1.4	35
BT200/1	2	1.5	2 (3)		-	12.2A	11A	1.8	69
BT300/1	3	2.2	2 (3)		-	12.2A	11A	1.8	72

MODEL	OUTPUT		DISCHARGE INCHES	PHASE VOLTAGE	3Ø			FREE PASSAGE	WEIGHT W/O CABLE
	HP	KW			208V	230V	460V	INCHES	LBS
BT50/3	0.5	0.37	2	FULL LOAD AMPS	3.1A	2.8A	1.4A	1.4	28
BT100/3	1	0.75	2		4.4A	4A	2A	1.4	35
BT200/3	2	1.5	2 (3)		7.7A	7A	3.5A	1.8	65
BT300/3	3	2.2	2 (3)		8.8A	8A	4.5A	1.8	69
BT500/3	4	3.7	3 (4)		16.6A	15A	8A	1.8	106
BT750/3	5	5.5	3 (4)		23.2A	21A	10.5A	1.8	119

MOTOR / PUMP CONSTRUCTION MATERIAL

PART	MATERIAL	PART	MATERIAL
Cable	H07RN-F/STJOW/STOW	Mechanical Seal	Upper: CA / CE
Handle	Nylon 6(0.5-1HP) AISI 316 (2-7.5HP)	Mechanical Seal	Lower: SIC / SIC
Motor Cover	AISI 316	Seal Housing	AISI 316
Bracket	ASTM A48 Class 30	Lip Seal	VITON
Motor Housing + Stator	AISI 316	Impeller	AISI 316
Shaft with Rotor	AISI 316	Pump Casing	AISI 316
Oil Chamber	ASTM A48 Class 30(0.5-1HP) AISI 316(2-7.5HP)	Upper/Lower Bearing	NTN/TPI

PUMP PERFORMANCE REPORT

MODEL	BT300		HEAD	RATED
FREQUENCY	60 HZ		45 ft / 13.7 m	
DISCHARGE	2 & 3 inches / 50 & 80 mm		CAPACITY	100 gpm / 378 lpm
OUTPUT	3 hp / 2.2 kW		POLE / RPM	2 poles / 3450 rpm

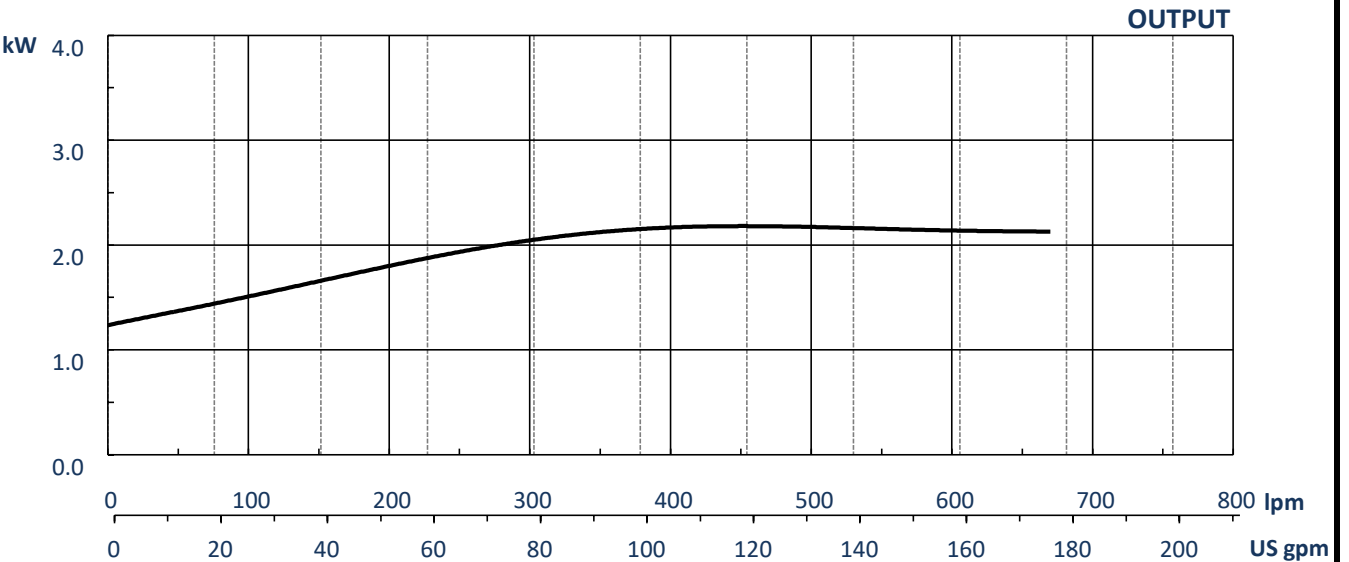
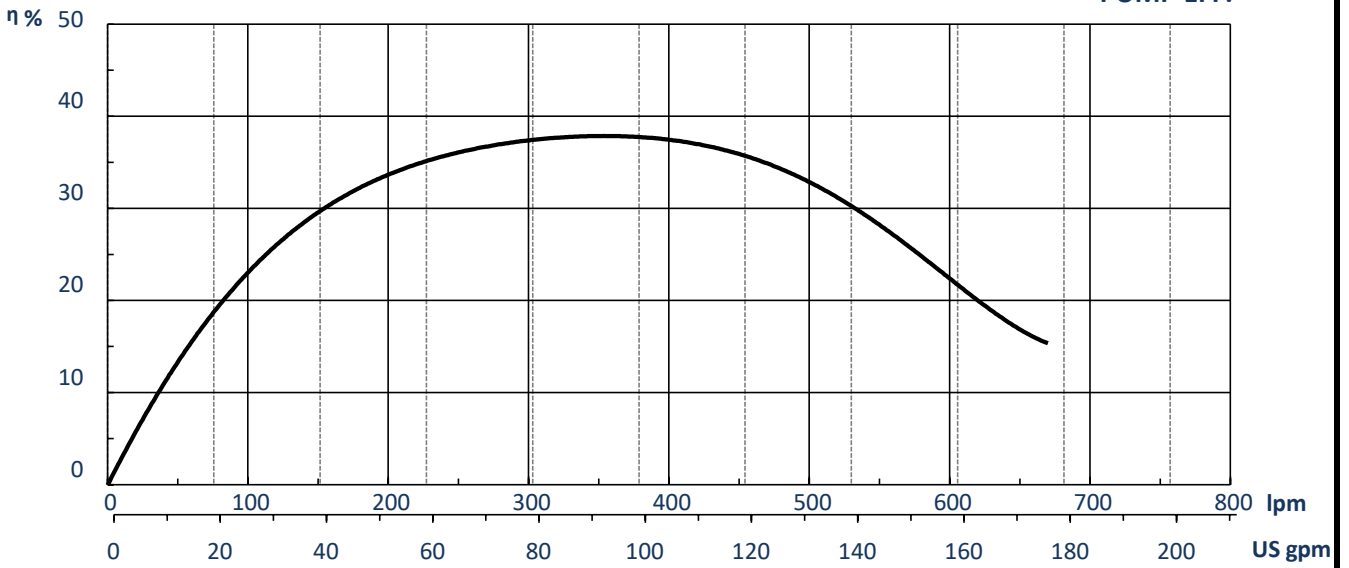
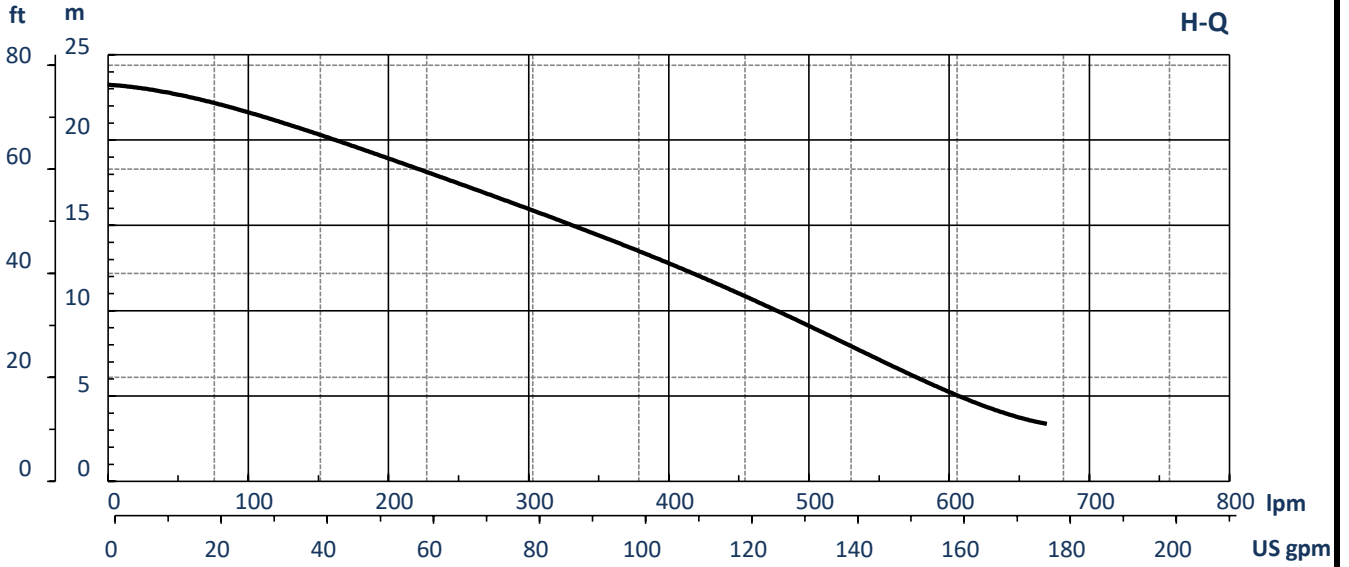

DIMENSIONAL DRAWING

MODELS: BT200 – BT300 (2~3HP)

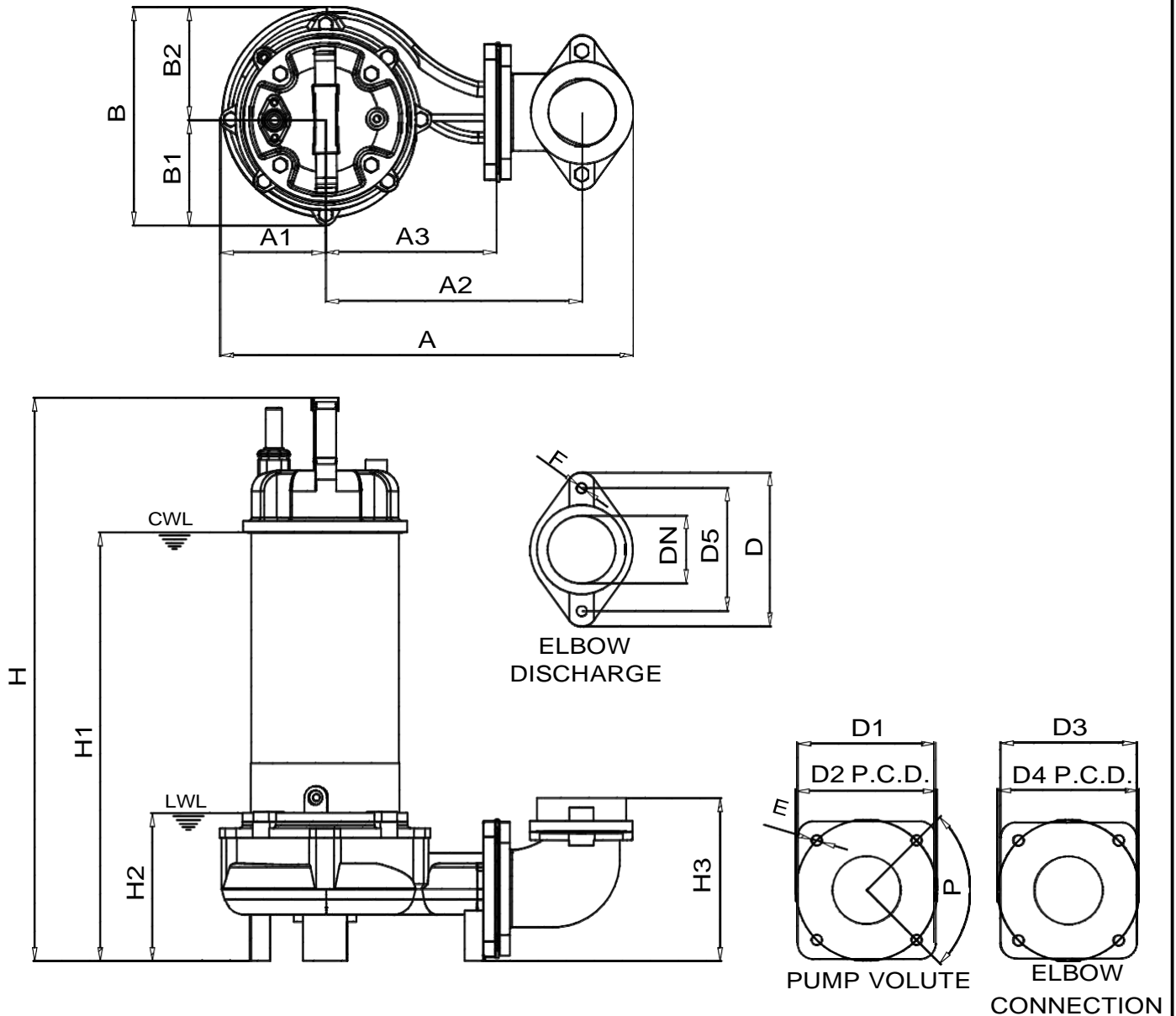

MODEL	A	A1	A2	A3	B	B1	B2	D	D1	D2	D3
BT200	15.35	4.06	9.25	6.06	8.19	4.09	4.09	5.91	5.20	5.31	5.12
BT300	15.35	4.06	9.25	6.06	8.19	4.09	4.09	5.91	5.20	5.31	5.12

MODEL	D4	D5	DN	E	F	P	H	H1	H2	H3	WT	
BT200	5.31	4.72	2 / 3	.39	.39	90	20.94	15.75	5.91	5.98	S: 69	T: 65
BT300	5.31	4.72	2 / 3	.39	.39	90	20.52	17.32	5.91	5.98	S: 72	T: 69

CWL: CONTINUOUS RUNNING WATER LEVEL
 LWL: LOWEST RUNNING WATER LEVEL
 WT: WEIGHT WITHOUT CABLE
 S: SINGLE PHASE T: THREE PHASE

DIMENSIONS: INCHES
 WEIGHT: LBS
 PIPE CONNECTION TYPE: NPT

Simplex control panels will control a 120/208/240V single phase or a 208/240/480V three phase pump in sewage pump chambers, sump pump basins, and lift stations. Simplex control panels come standard with a clear front NEMA 4X rated enclosure, an IEC rated contactor, and a motor protective switch.

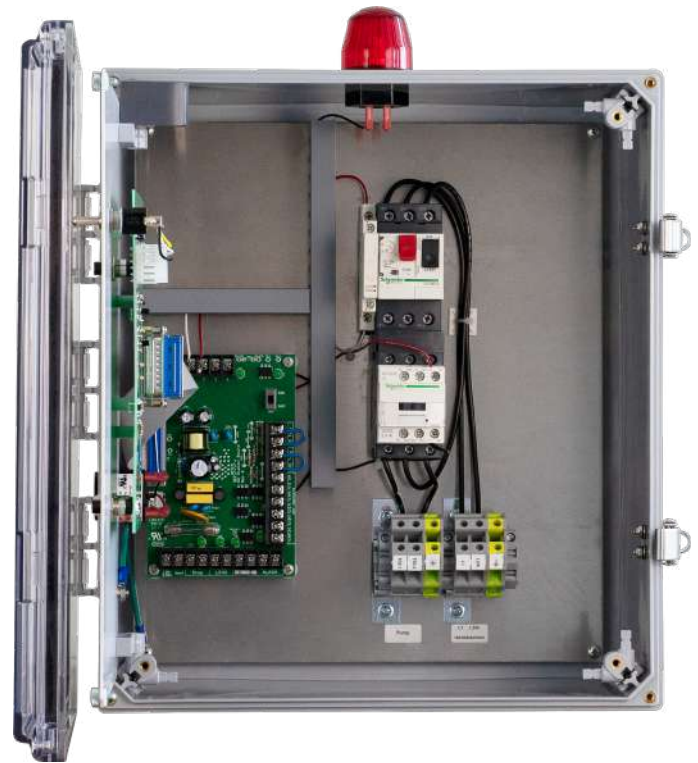

Features

- Pump control visible indicators: Pump hand-off-auto (H.O.A.) switch, green Pump Run light, red Pump Fault light with reset button, and Power On light
- Alarm visible indicators: High red beacon alarm light, alarm test and silence buttons
- Alarm horn sounds at 85 decibels at 10 feet
- Remote monitoring by dry contacts: High Liquid, Pump Fault, Pump Run
- Upgraded pump protection: Motor protective switch (branch circuit protection, adjustable overload and disconnect) and a thermal cutout with indicator

Applications

- Sewage pump chambers
- Grinder pumps
- Sump pump basins
- Lift stations



Simplex Single Phase: 120/208/240VAC

Model	Pump Full Load Amp Rating
WS1P-TP-1001	0-7.0 FLA
WS1P-TP-1002	7.0-15.0 FLA
WS1P-TP-1003	15.0-22.0 FLA
WS1P-TP-1004	22.0-28.0 FLA
WS1P-TP-1005	28.0-36.0 FLA

Note: Thermal overload protection is generally provided in single phase pumps. To request a specific overload on the single phase models, contact the factory. Each panel includes a motor protective switch that will provide accurate pump circuit breaker protection.

Simplex Three Phase: 208/240/480VAC

Model	Pump Full Load Amp Rating
WS3P-TP-3001	1.0-1.6 FLA
WS3P-TP-3002	1.6-2.5 FLA
WS3P-TP-3003	2.5-4.0 FLA
WS3P-TP-3004	4.0-6.3 FLA
WS3P-TP-3005	6.0-10.0 FLA
WS3P-TP-3006	9.0-14.0 FLA
WS3P-TP-3007	13.0-18.0 FLA
WS3P-TP-3008	17.0-23.0 FLA
WS3P-TP-3009	20.0-25.0 FLA
WS3P-TP-3010	24.0-32.0 FLA
WS3P-TP-3011	30.0-40.0 FLA
WS3P-TP-3012	37.0-50.0 FLA
WS3P-TP-3013	48.0-65.0 FLA
WS3P-TP-3014	65.0-115.0 FLA

Typical Installation of Simplex Control Panel



Custom Options

Option(s)	Description	Option(s)	Description
24	Pump Exerciser	LAD/LAW	Lightning Secondary Surge Arrestor (LAD Delta / LAW Wye)
28	Power On Dry Contact (Normally Open)	LL	Low Level Alarm
3R	Painted Steel Enclosure	MD	Main Disconnect; Up to 125 FLA
AF	Alarm Flasher	MD2	Main Disconnect; 125 to 200 FLA
AH	Anti-Condensation Heater	PM	Phase Monitoring
C	Additional Cord Length Per Foot Per Component*	PX	Pump Portal® Wireless Remote Communication
CC	Cycle Counter w/LCD Display and Reset	SF	Seal Failure Circuit w/ Indicator Lights
CO	Convenience Outlet (User to supply 120 VAC)	S3	No Floats Option
ETD	Elapsed Time Meter w/ LCD Display and Reset	SS4	Upgraded Enclosure (304 Stainless Steel)
GR	Generator Receptacle, Includes Transfer Switch	SS6	Upgraded Enclosure (316 Stainless Steel)
IS	Intrinsically Safe		

*Additional cord length greater than 20': Specify after C. Example: WS1P-TP-1003-C50. Indicates 50' cord lengths for all floats.

NORMALLY OPEN MECHANICAL FLOAT SWITCH X 30 FT

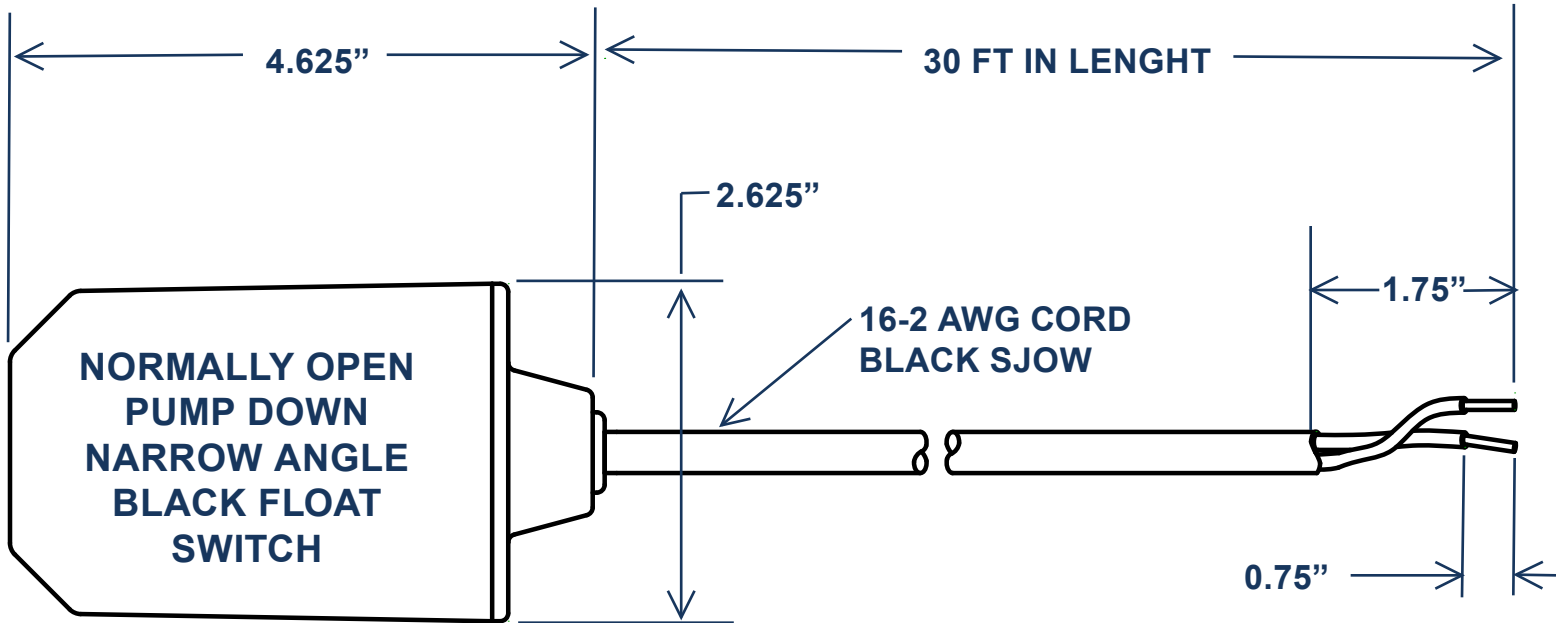

OPERATING ANGLE: CONTACTS CLOSED @ 25° ABOVE HORIZONTAL CONTACTS OPEN @ 10° BELOW HORIZONTAL

ELECTRICAL RATINGS: 1/4 H.P. @ 120/240 VAC
10 AMPS @ 120/240 VAC 34.8 LRA

FLOAT MATERIAL: A.B.S.

FLOAT WEIGHT



10-24 UNC PHILLIPS PANHEAD
7/8" LONG STAINLESS STEEL
(2 PER SET)



WEIGHT: TOTAL WEIGHT OF ASSEMBLED PRODUCT IS 1LB 4 OZ AND CAN VARY BY 2OZ

MATERIAL: GREY IRON

FINISH: 1 MIL ZINC PLATING

